



Central Station



**Controlling
Switching
Running**

Central Station

-  = Operating step(s) Märklin
-  = Operating step(s) DCC

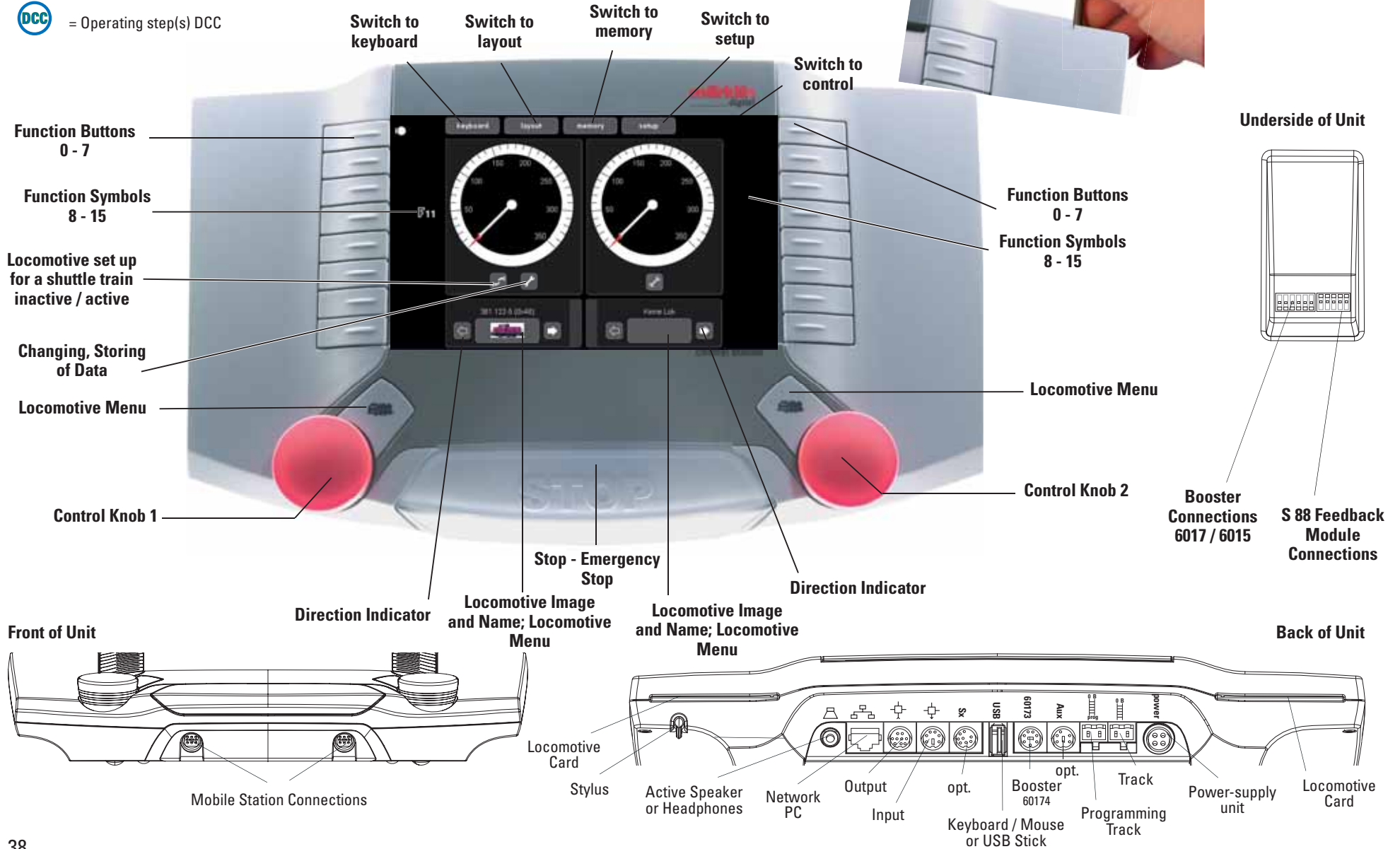
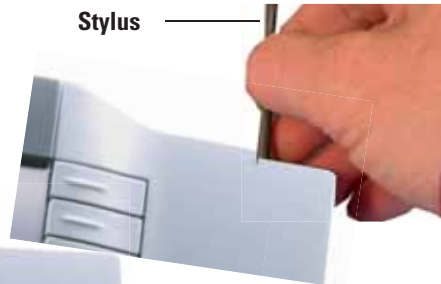

Getting Set Up and Started

Preparations

The following components are required to get started:  

60 VA power-supply unit, connecting cable between the power-supply unit and the Central Station, connecting wires between the Central Station and the track layout, rolling stock and/or solenoid accessories.

Connect the parts as shown in the following illustrations.

Connecting the power supply to the Central Station and calibrating the touchscreen (Display) when turning the Central Station on the first time.

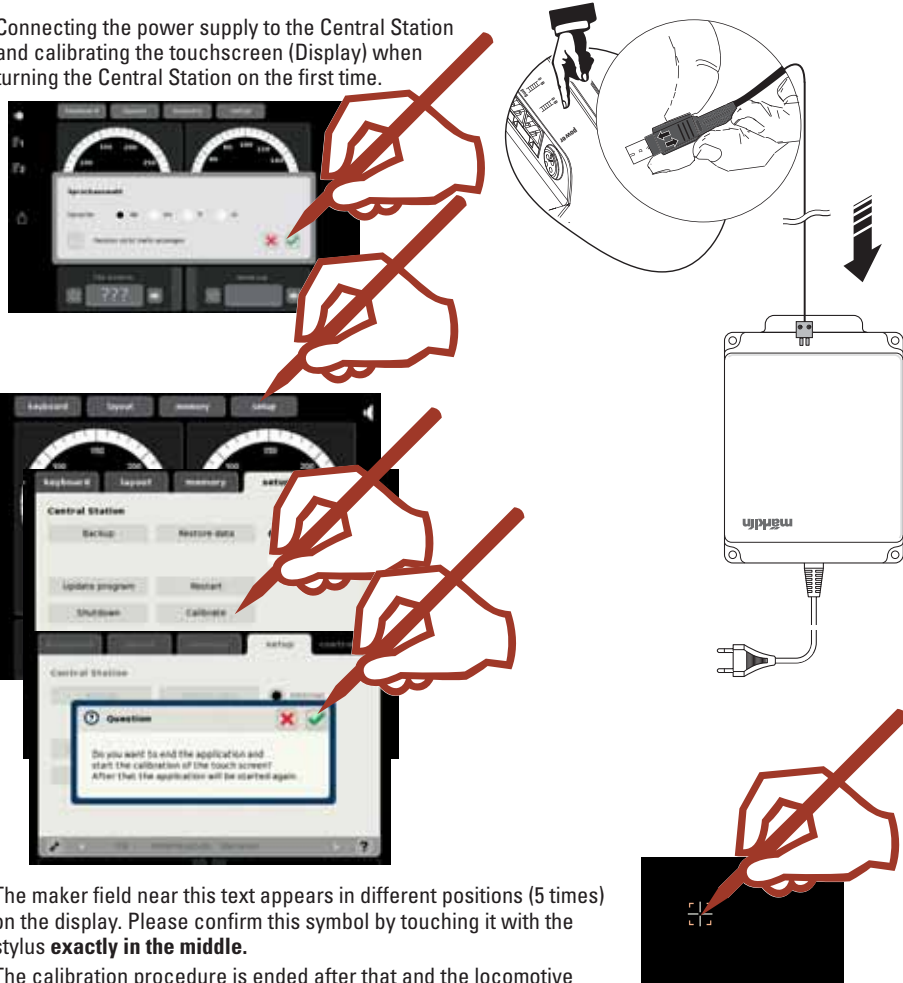

The maker field near this text appears in different positions (5 times) on the display. Please confirm this symbol by touching it with the stylus **exactly in the middle**.

The calibration procedure is ended after that and the locomotive controller display will appear after a short time.

Connections to the Layout  

Connections to C Track or Connections to K Track or 1 Gauge feeder connection and/or 

The only possible connections are those shown!

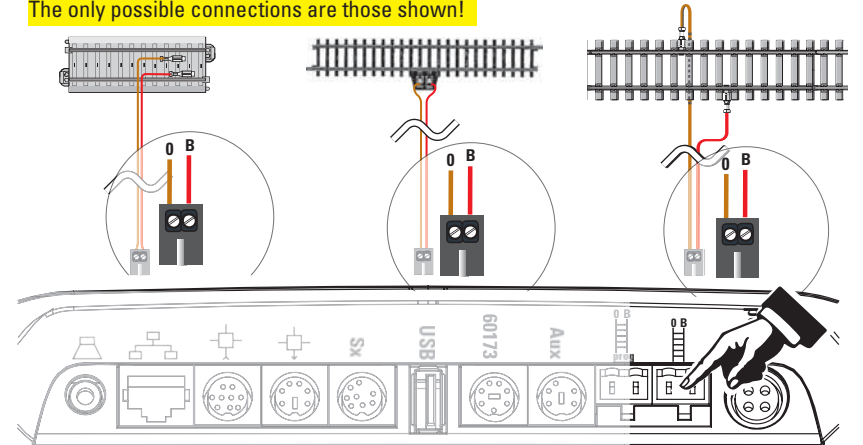

Connections to the Programming Track  

The programming track may not have any direct electrical contact with the layout, nor can it have additional users (examples: lighting, turnout decoders, light track bumper, etc.) connected to it. The programming track is required to read out, program, and process locomotive decoders.

C Track Programming Track or K Track Programming Track or 1 Gauge programming track and/or 

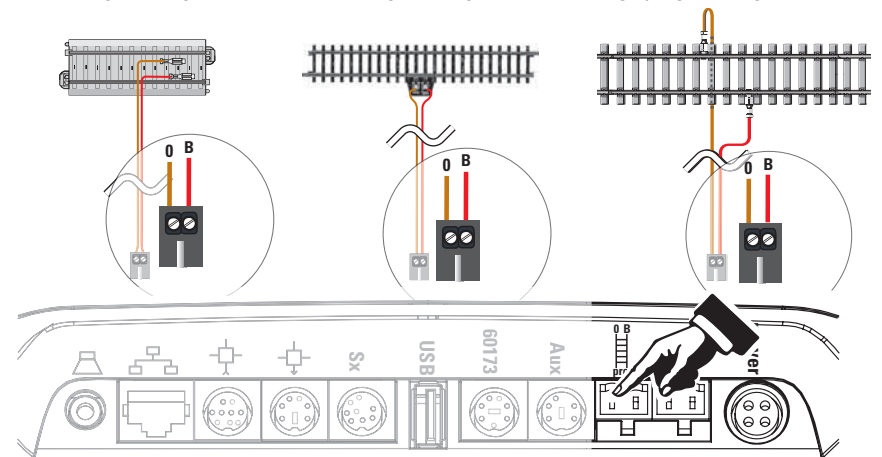

Getting Set Up and Started

Selecting and Running a Locomotive

Registering mfx locomotive M



Data from the mfx locomotive completely read in.

Confirm

The mfx locomotive is ready to run and can already be operated. If it becomes necessary, we recommend that the locomotive be added to in the locomotive list as shown starting on Page 47.

mfx locomotive recognized

Selecting a Locomotive M



You can start immediately if one of these locomotives is part of your roster:

(101 047-9 with address 1, BR 85 006 with address 8) then continue as described nearby under "Running a Locomotive".

Or

Select a controller and continue with the following steps.

Select one of your locomotives in the database.

This only works if the settings done at the factory for the locomotive have not been changed.

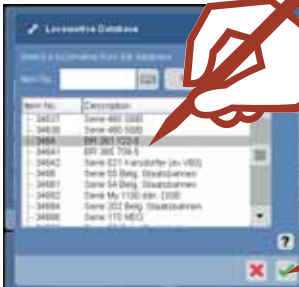
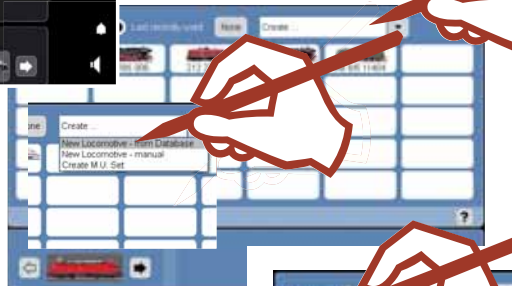

Confirm selection.

Running a Locomotive

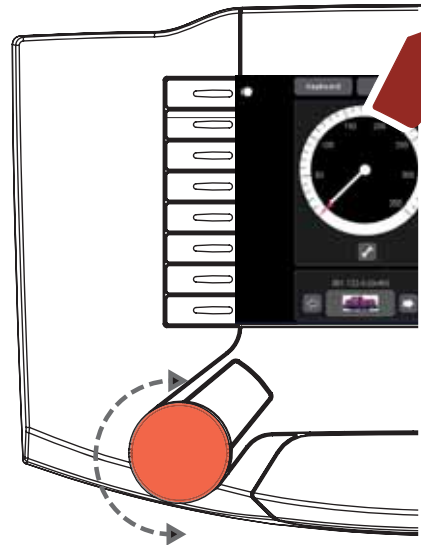

Function switch

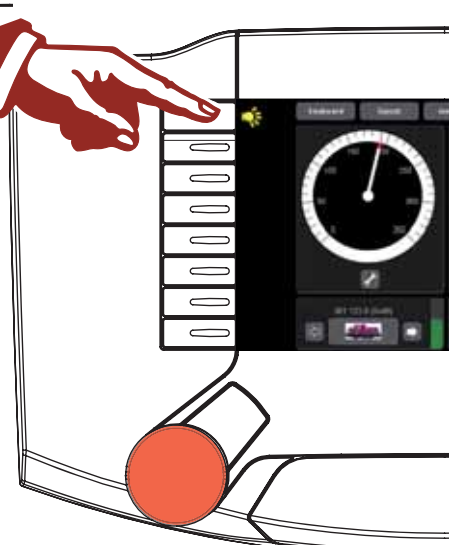

Selecting and Controlling Solenoid Accessories M

Selecting



Controlling

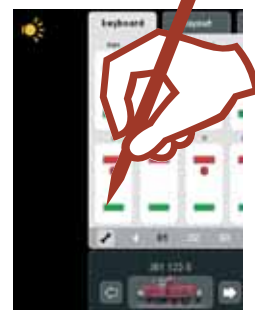

All accessory addresses are available without prior programming. These addresses are arranged in ascending order and can be confirmed with the standard keyboard.

Getting Set Up and Started

Selecting and Running a Locomotive

Loading the Basic Configuration for DCC

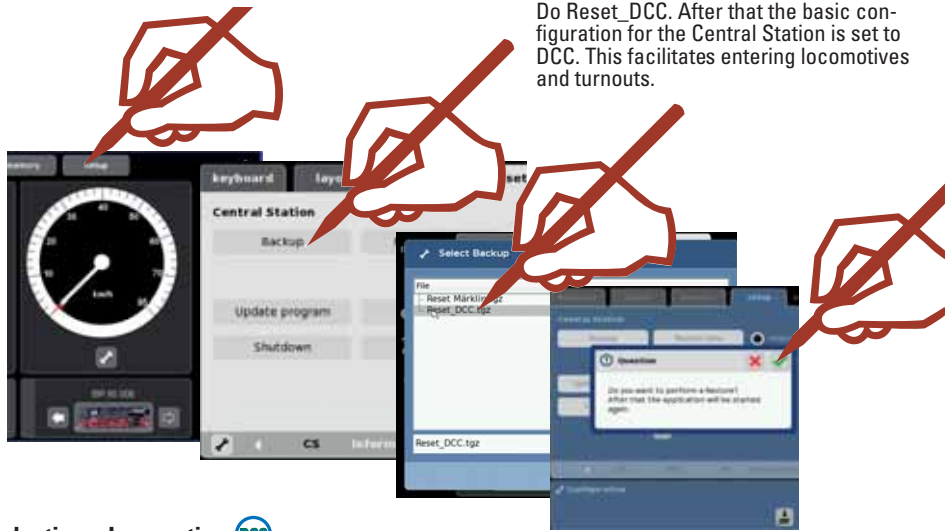

Do Reset_DCC. After that the basic configuration for the Central Station is set to DCC. This facilitates entering locomotives and turnouts.

Selecting a Locomotive



You can start immediately if this locomotive or a locomotive with address 3 belongs to your motive power. Then continue as described nearby under "Running a Locomotive".



Or

You enter your locomotives as described on page 47 under "Programmable Locomotive".

Running a Locomotive

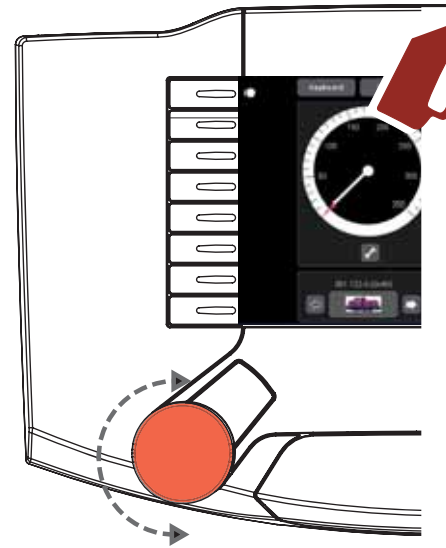

Function switch

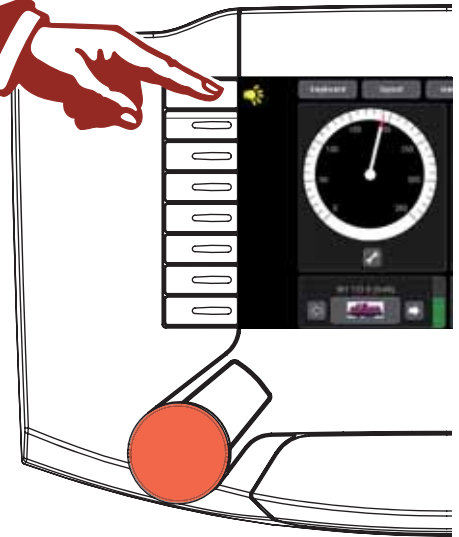

Selecting and Controlling Solenoid Accessories

Selecting



2,048 addresses are available. These are arranged numerically in ascending order and can be activated from a standard keyboard.

We recommend that you check the settings for the type of decoder before using it. => Page 56/3-5.1

Controlling

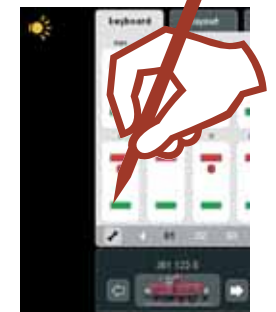



Introduction

The fourth generation of Märklin multi-train control systems is now ready with this “Märklin Digital”. The most important component is the Central Station, which is responsible for the generation of the correct control data, which carries out the coordination of the components connected to it, and which also offers an easy-to-use manageable operating surface. Trouble-free operation with this complex system is only ensured when you use only tested Märklin system components. Märklin’s manufacturer’s warranty therefore becomes invalid if you use any other make of product with the Central Station. The operator is thereby responsible for damages arising from the use of other makes of products.

Adhere to the techniques and principles presented in this instruction manual when connecting your layout to the Central Station. The use of other circuits can easily lead to damage to the electronic components. It is therefore best if you refrain from “expensive” experiments. The Central Station is not a toy. Make sure that this device is also used by children only as a controller for a model railroad.

We hope you will have a lot of enjoyment using the Central Station with your model railroad layout.

With this Central Station you have a device that offers you extensive possibilities for controlling your model railroad. We recommend that you work through the examples presented in this handbook. You will thereby have a much greater level of reliability in using the Central Station.

Your Märklin Service Team

Notes for the Central Station

Do not expose the Central Station to moisture.

This Märklin product is not watertight. Malfunctions can occur if there is high humidity or if moisture gets inside the housing. The corrosion of the internal mechanism and electronics can lead to irreparable damages.

Do not expose the Central Station to shock.

If this controller is exposed to blows or strong vibrations, the result can be continuous malfunctions.

Do not expose the Central Station to extremes of temperature.

Sudden changes in temperature can cause moisture to condense inside the housing. In order to avoid condensation buildup, you should keep the Central Station protected and you should protect it during transport before you change to a location with much higher or lower temperature.

Do not use force when operating the buttons and control knobs on the Central Station.

Do not use force when operating the buttons and control knobs on the Central Station.

Safekeeping

Do not keep the Central Station in locations where the following unfavorable conditions prevail:

High humidity or bad ventilation.

Temperatures over 50° Centigrade / 122° Fahrenheit (such temperatures can occur for example in direct sunlight) or under -10° Centigrade / 14° Fahrenheit.

Humidity over 60%.

The humidity must not be greater than that for Central Europe.

Cleaning

Remove lint and dust with a soft, dry or slightly moist cloth. Never use alcohol, thinners or other strong cleansers.

Technical Specifications

Power Output When Used with the 60061/60101 power-supply unit

Input voltage: min. 14 V = / max. 24 V ~

Load: Train operating track 3 amps / 5 amps

Programming track 1.0 amps

Maximum 5,0 amps

Please take note of the specifications in the Help function for this unit so that you can make full use of the total possible load.

Display resolution: 800 x 480 Pixels with 16 Bit color depth

Possible Connections

Power-supply unit

Programming track

Mobile Station

Feeder track

Network: Ethernet

USB: for a mouse, keyboard, and/or memory stick

Booster: 6015, 6017, or 60174

Feedback Module: S 88

Aux: currently not used

Outlet: Connections for a Central Station (60213/60214/60215), the Terminal 60125 or from the Connect 6021

Input: Connections for a Central Station (60213/60214/60215) as an Auxiliary or Second Unit

SX-Bus: (Currently not used).

Headphones or active speakers (Currently not used).

Technical Note for the Central Station

Only standard, hooded USB sticks with an ferrite core may be plugged into the USB connection.

Digital Protocols:

The following digital protocols are supported:

Märklin Motorola, mfx, 

DCC adhering to NMRA/NEM standards. 

Software:

Parts of the software for the Central Station are subject to the software license GPL.

You can get the source code for these software parts at no charge from Märklin, either as a CD or by downloading a CD image from the Märklin home page.

More complete and updated information can be found on our Internet pages “www.maerklin.com”

If an error or defect should occur, do not open the Central Station. Send the defective unit to the Märklin Service Department or to one of our service stations listed on our Internet page.

Opening this unit cancels any and all warranty claims. The individual and/or firm or customer responsible for opening the Central Station bears the burden of proof and demonstration that opening the unit did not cause the defect that has occurred and/or damages.

Control

Running • Entering • Managing

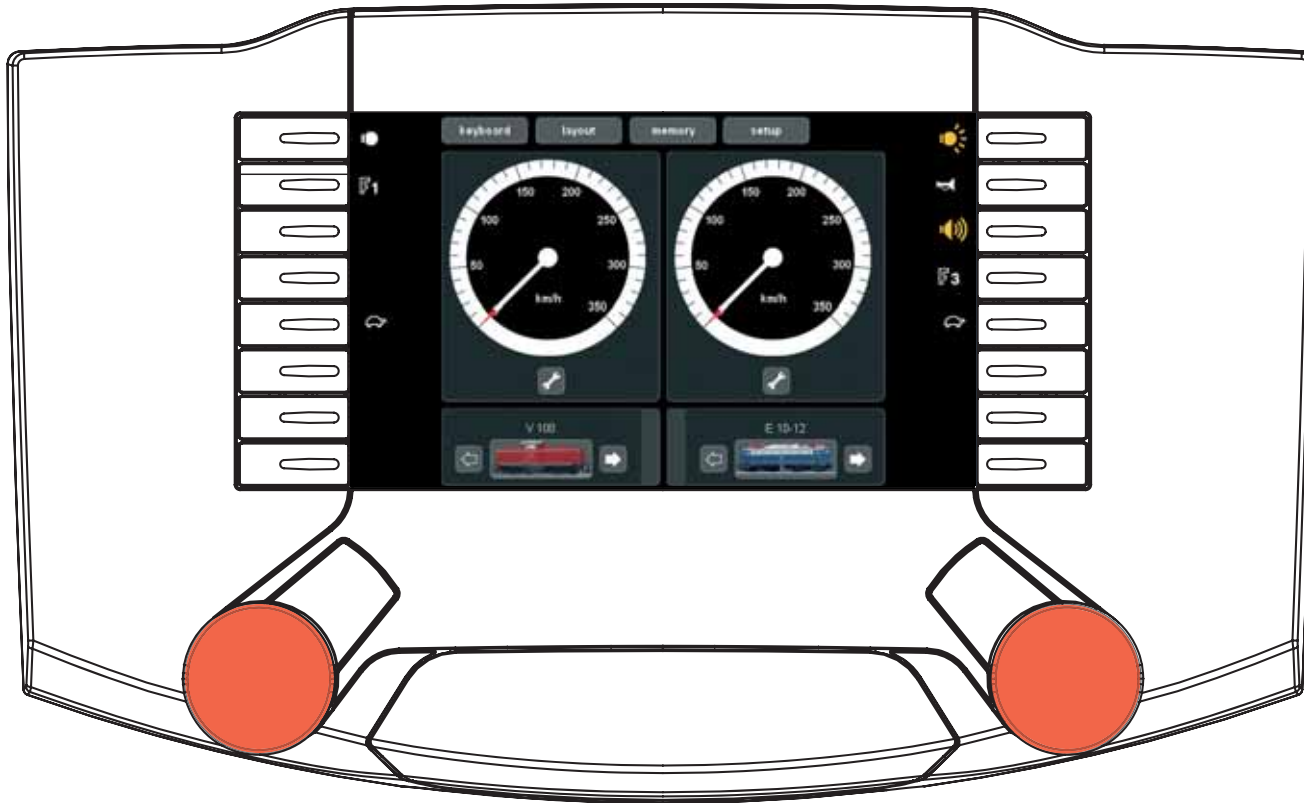

Locomotives and powered units can be entered, run, and managed with the Control.

Selecting and Running M DCC

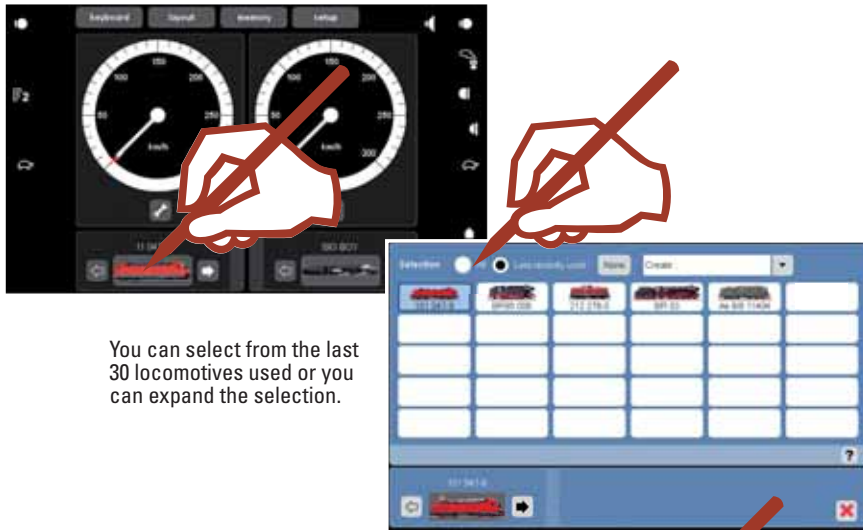

You can select from the last 30 locomotives used or you can expand the selection.

The most frequently used locomotives are available for you to select in this list.

All of the locomotives taken by you into the locomotive list are in this list for you to select.



Now you can run the locomotive you have selected with the control knob or by typing in the desired speed on the screen. The functions can be activated by pressing on the button or by typing in the symbol.

Locomotive with an mfx Decoder M

Registering and/or taking into the locomotive list.



Place your locomotive with an mfx decoder on the programming track. This can also be done while the layout is in operation. The locomotive registers itself as shown in the following illustrations. The registration can be done with an icon and locomotive name as well as without. Additional processing as described starting on Page 48 will be necessary depending on the registration.



mfx locomotive recognized.



Data from the mfx locomotive completely read in. Confirm.



The mfx locomotive is ready to run and can already be operated. If it becomes necessary, we recommend that the locomotive be added to the locomotive list as shown starting on Page 48.

Entering: **M** **DCC**

- New locomotive manually: Introduction and Preparation **M** **DCC** ⇒ Page 45
- Locomotive with DIP Switches **M** ⇒ Page 46
- Programmable Locomotive **M** **DCC** ⇒ Page 47

Labels for the Configuration Lok app interface:

- Online Help
- Locomotive Description
- Opens Keypad
- small or large
- Select Icon
- Symbol Selection for the Display on the Mobile Station
- Locomotive Address or opens the 10 digit keypad
- Read Locomotive Address
- Read Status Display
- Switch Settings Decoder/Address 4 or 8 DIP Switches
- Save Data
- Cancel without Saving
- Confirm and Save

Whenever you see this ?, the Help function is available for you to use and will take you through the operation of the application you are asking about.

Tip:

Basically, the decoders can be used in mixed operation. You can decide by address which protocol will be assigned to the latter and which protocol will be supported by the decoder.



Enter locomotive name: ex. Class 03.

3 x ←

Select icon.

Select an icon that goes with your locomotive.

Confirm selection.

With DIP Switches M
 Programmable locomotive ⇨ Page 47

If the locomotive is standing on the **programming track**, you can read out the address for it.

or

enter a decoder address.

Check the settings for the decoder.

If all of the desired settings have been done, then confirm and save.



The locomotive has been taken into the locomotive list.

You can find additional possible settings in the section "Configuring a Locomotive". Page 48

Programmable Locomotive:  

Read or enter.

Place the locomotive on the programming track!



Selecting the decoder type.

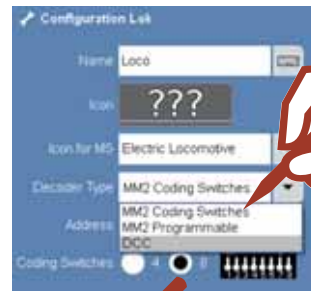

 oder 

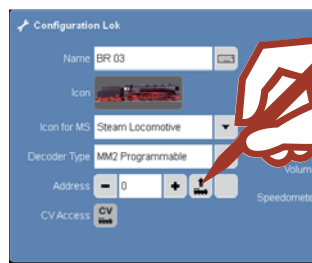

Reading the existing decoder address.

Confirm.



You can do other settings that influence the locomotive's running characteristics when controlled with the Central Station. The settings can be done in the fields with "-" or "+". In our example: acceleration and braking delay as well as the speedometer.



Confirm, or if changes have been made, transfer them to the locomotive.

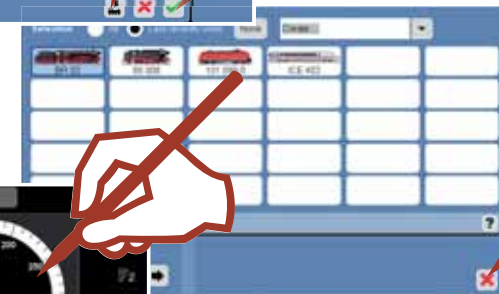

The locomotive is now entered. It can be added to or changed as shown starting on Page 48.

Configuring a Locomotive

Adding to / changing symbols, functions, and settings. This function can be used for all types of decoders. However, only those settings and functions available on the computer can be processed. In the example of a locomotive with an mfx decoder we are showing you the multifaceted possibilities for these settings.

The locomotive to be processed should be called up on one of the two controllers. Then go with this locomotive to the configuration mode as shown here.



In the configuration mode there are additional icons available for the supplementary setup of the locomotive.

Changing CVs (Parameters)

! Please note that not every locomotive supports all functions and characteristics. Please refer to the instructions that came with your locomotive. There you will find information regarding what functions and characteristics the locomotive's decoder supports.

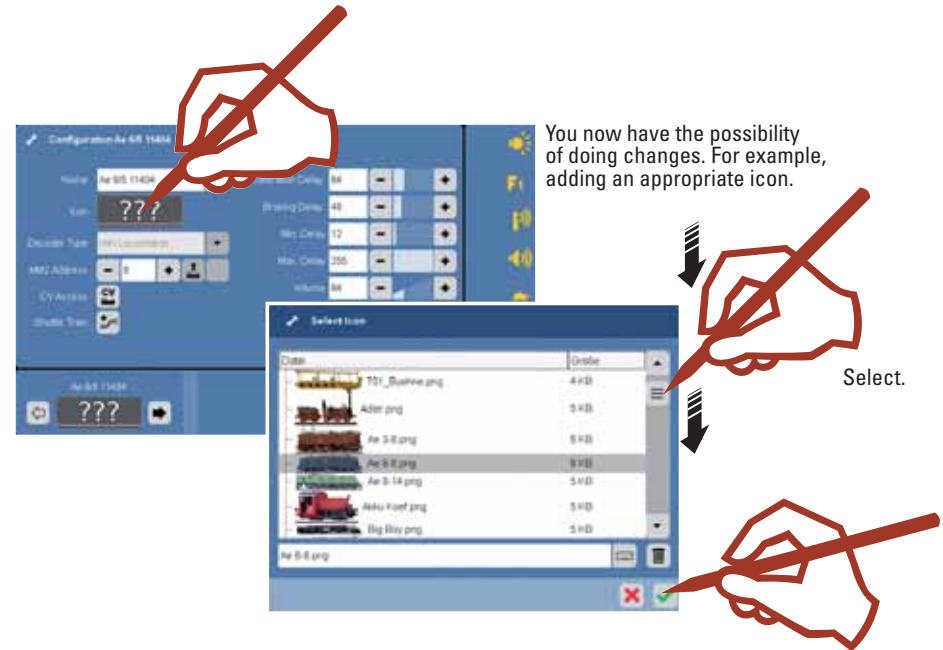
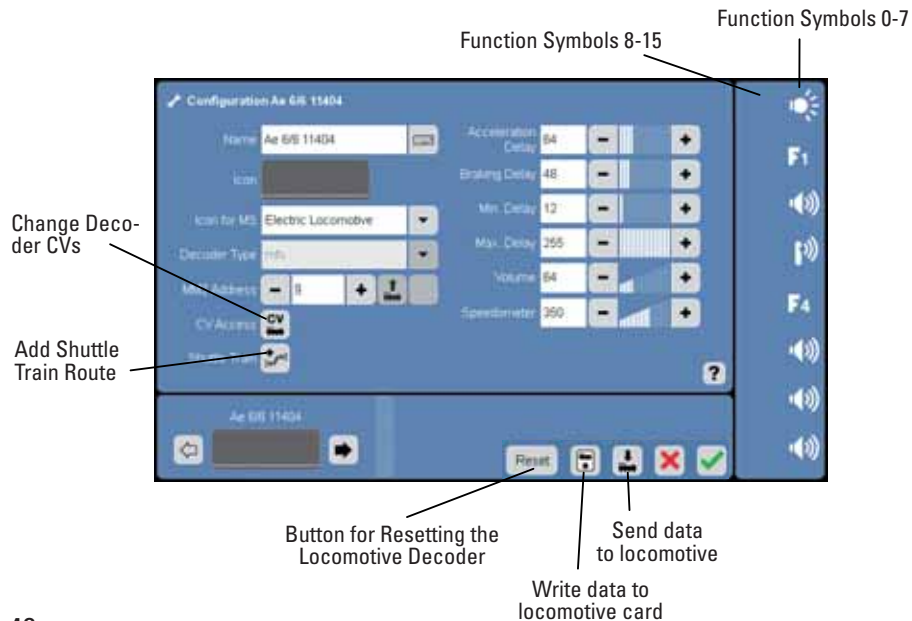

You now have the possibility of doing changes. For example, adding an appropriate icon.

Select.

Confirm.

Adding a Shuttle Train Route

Here, you have the possibility of assigning a shuttle train route.

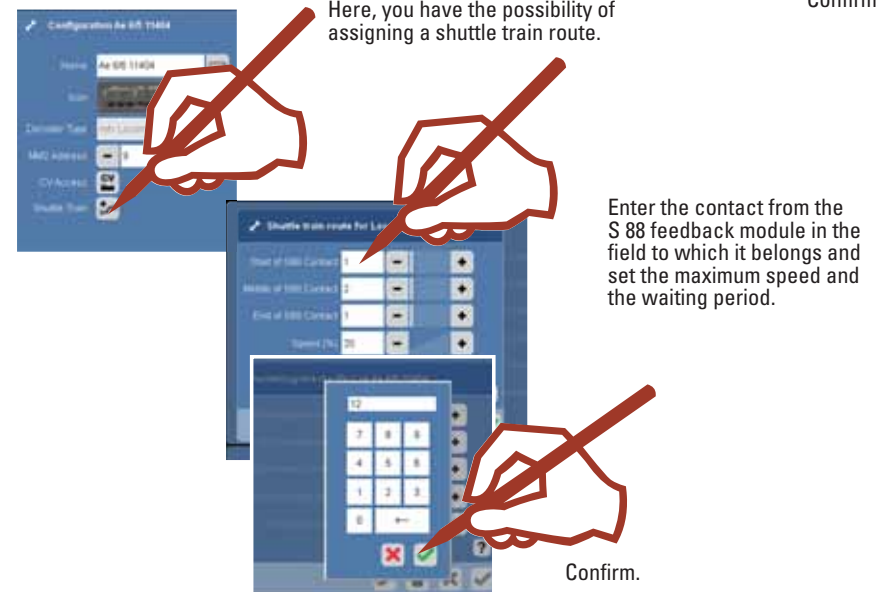

Enter the contact from the S 88 feedback module in the field to which it belongs and set the maximum speed and the waiting period.

Confirm.



Deletion of the shuttle train route for this locomotive

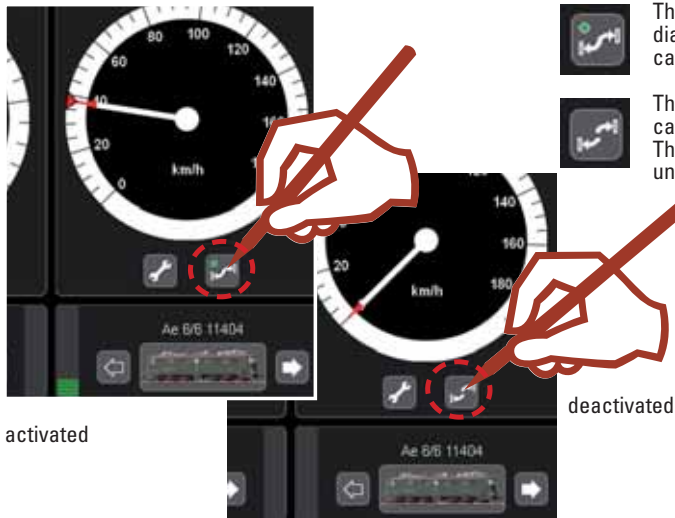

The shuttle train is now immediately active; the locomotive can now be used only for this.



The shuttle train is set up and can be activated at anytime. The locomotive can be used universally.

activated

deactivated

Changing or Adding Function Symbols.

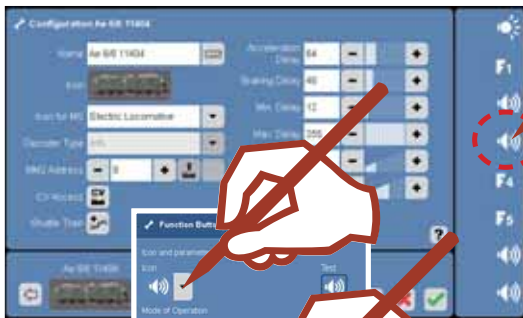

select

You have the possibility of assigning a type of function to the functions:

- Switching function on/off (ex. lights)
- Momentary impulse function (ex. Telex couplers)
- Duration function (ex. whistle)

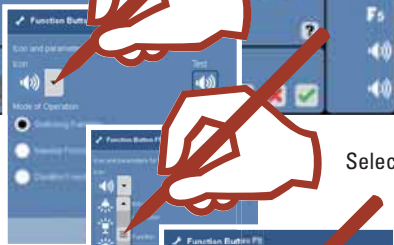

Select a function symbol.

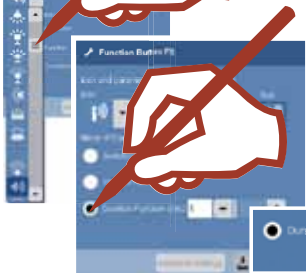

Select a function symbol, example: duration function.

Select the duration.

Changing CVs (Parameters)

! Please note that not every locomotive supports all functions and characteristics. Please refer to the instructions that came with your locomotive. There you will find information regarding what functions and characteristics the locomotive's decoder supports.

Here, you have the possibility of changing the CVs on certain locomotive decoders.

! This is a far-reaching intervention into the behavior of the decoder and can lead to the decoder becoming unusable when incorrect entries are made.

Please use the instructions for your locomotive and our extensive help resources when doing this.

! **Note:** Settings for the address (CV 1) and the number of speed levels (CV 29) should never be changed using the CV table. There is a simple programming maneuver for this on the configuration for the locomotive.



The locomotive is reset to factory default settings if this is supported by the decoder.

The locomotive data are written to the locomotive card.

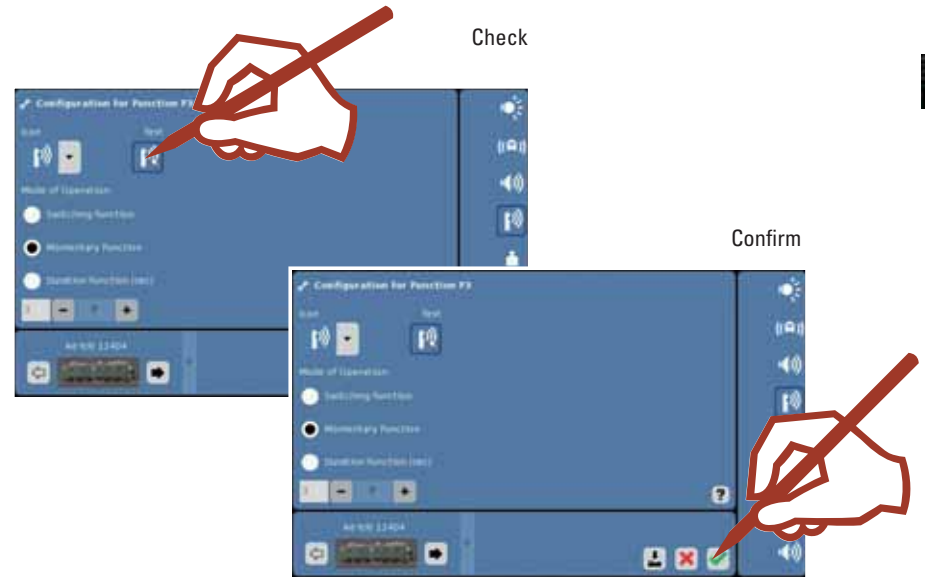

Check

Confirm

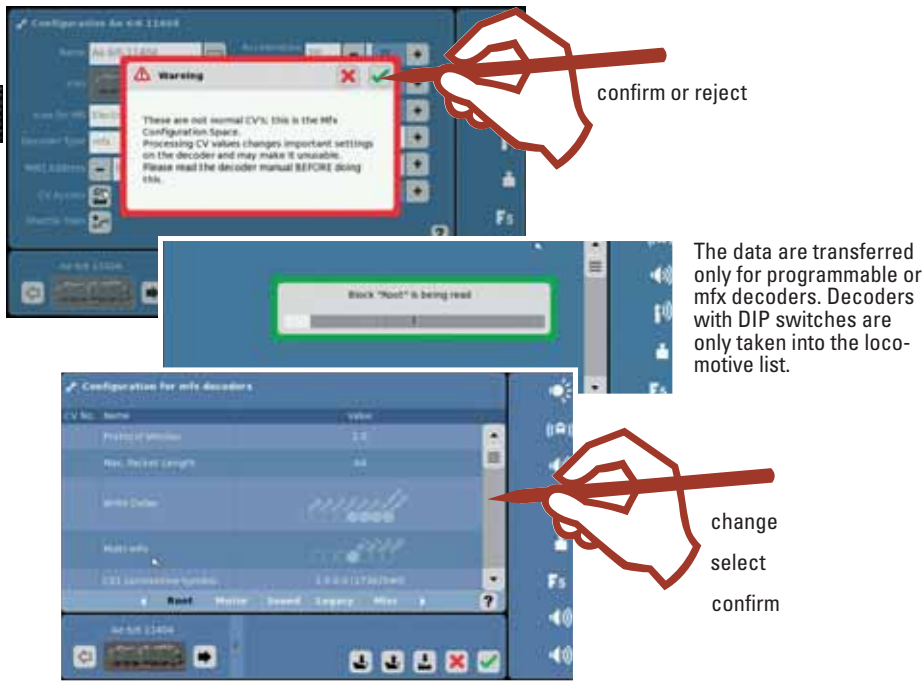

confirm or reject

change
select
confirm

Example: Function Mapping

Adding another function

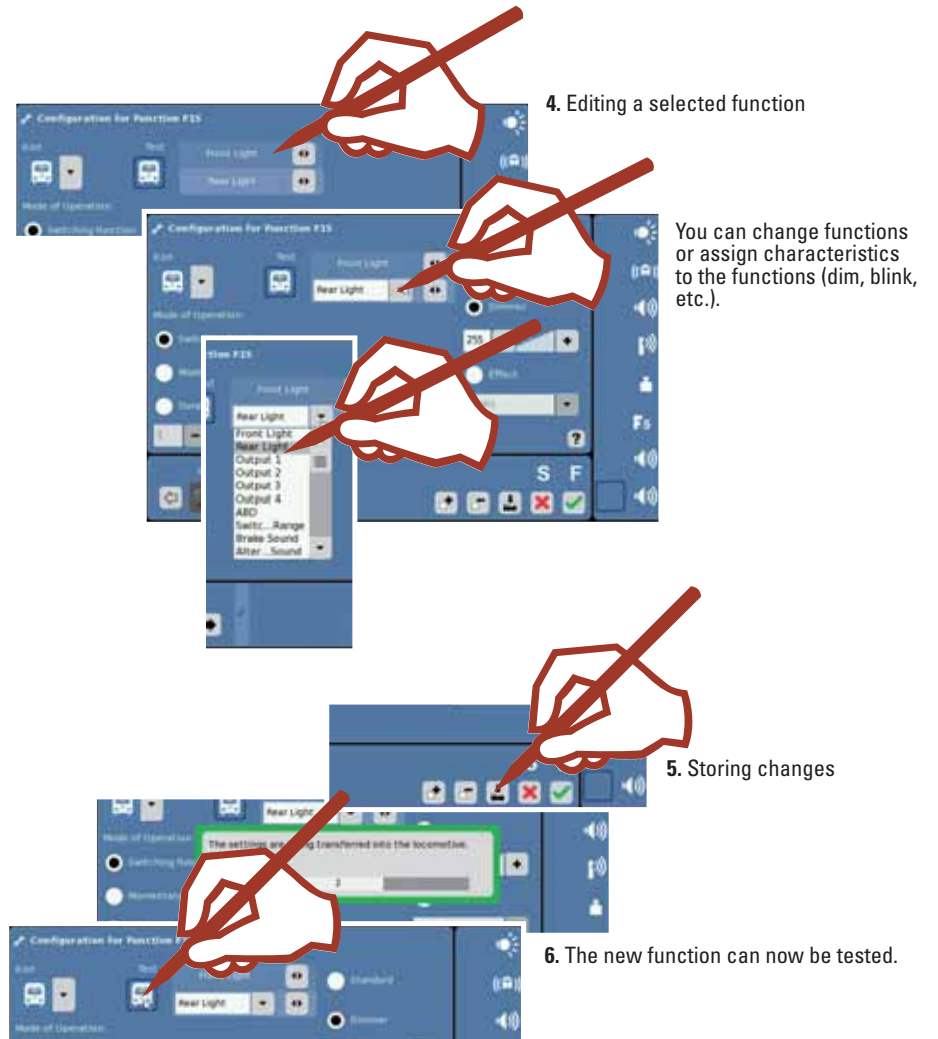
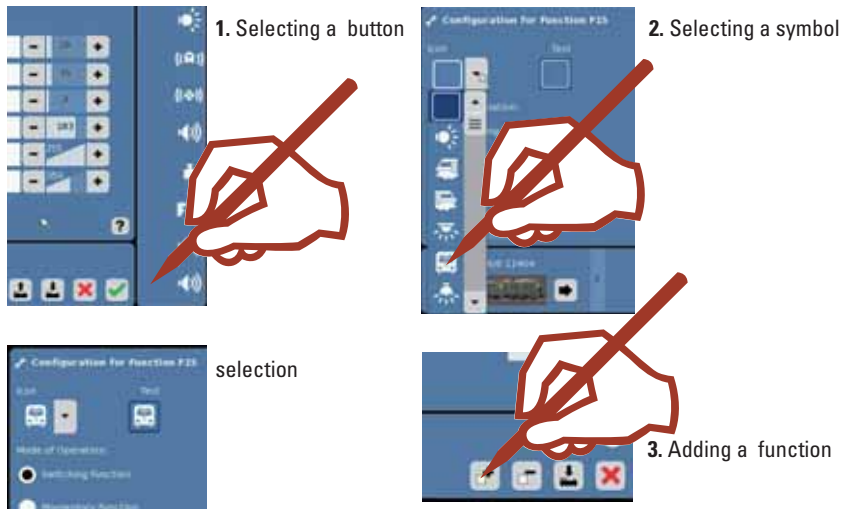

You can insert, change, or store other functions.

Data are transmitted and the configuration mode is closed.

Functions when the locomotive is stopped or running



Here you can set up a function that works when the locomotive is stopped (S) or is running (F). Steps 1-6 already explained above are used to set this function up.

Example of an ABV parameter

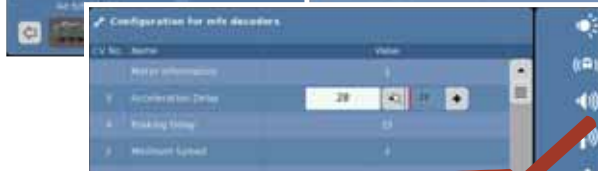

The CVs selected here are stored directly in the decoder and directly influence the locomotive's running characteristics, example: the braking and acceleration in the area for a braking module.



Storing changes and then continuing with other CV settings or finishing the process with the green check mark.

The newly entered or changed locomotives are now ready to be run with the Central Station.



Important Note!

Carry out the function "Shutdown" before turning the Central Station off, in order to ensure that all data are saved. If you suddenly turn the Central Station off, you may lose data.

Programming On The Main (POM)

Programming On The Main (POM) is a special form of programming in which the locomotive is programmed while it is running; i.e. the locomotive does not have to be standing on the programming track and does not have to be stopped. POM must be supported by the decoder being used (see decoder instructions) and even then only individual settings can be programmed with POM. You can store and access CV tables specific to certain locomotives.

You cannot read out values from the decoder / locomotive with POM.



Note: Settings for the address (CV 1) and the number of speed levels (CV 29) should never be changed using the CV table. There is a simple programming maneuver for this on the configuration for the locomotive.

Accept locomotive from Locomotive Card

You can accept locomotives from existing cards or write to a locomotive card.

Read:

Insert the locomotive card as shown into the card reader. The data are taken into the locomotive list, and you can start.
!Make sure that the chip on the card is facing down.

!Make sure that the chip on the card is facing down.

Write: (only in the configuration mode)

Insert the locomotive card as shown into the card reader. Press the symbol. Locomotive data is written to the locomotive card.

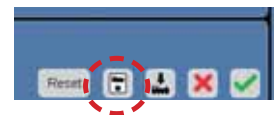

Locomotive data is being transferred to the locomotive card.



Entering an M.U. Consist

An m.u. (multiple unit) consists of at least 2 locomotives. You can however also have several locomotives in a consist. The number of locomotives is limited by the current draw for users in the power consumption area.



! Only locomotives similar to one another in their running characteristics should be used in an m.u. consist.

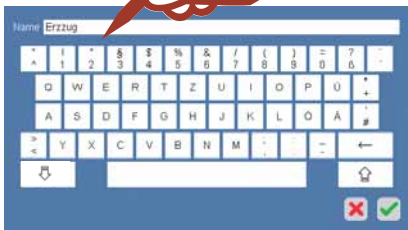
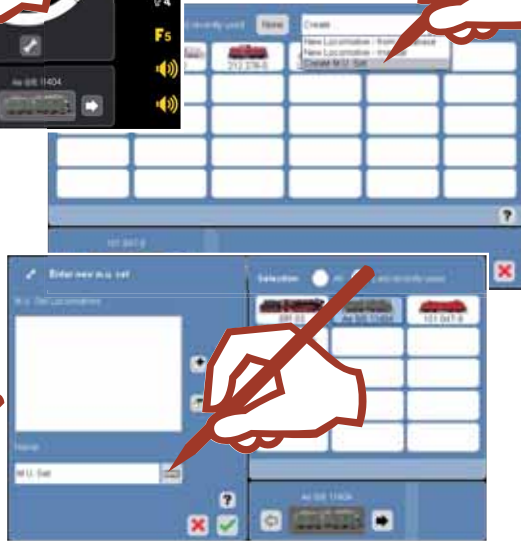

← Delete existing text.
 Enter new name, ex. "Ore Train".
 E R Z Z U G

Add the first locomotive in the m.u. consist.

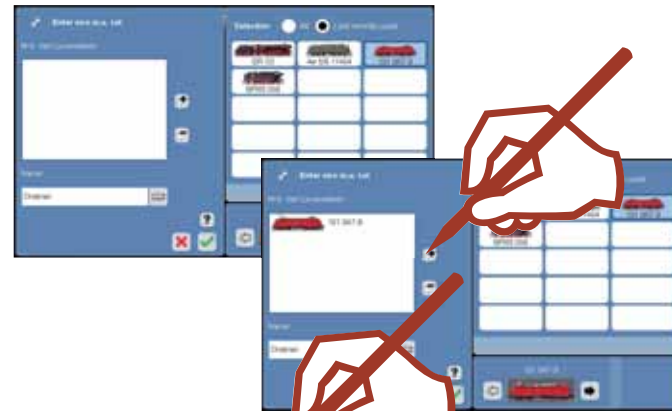

Go to the next locomotive.

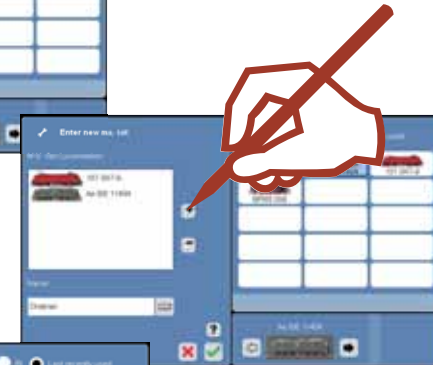

Add the locomotive to the m.u. consist.

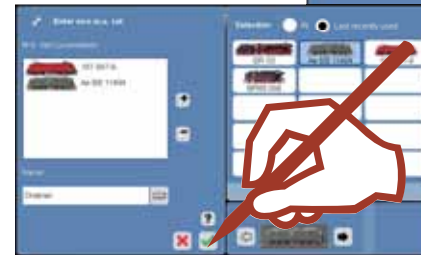

Confirm entry

The motive power consist has been taken into the locomotive list.

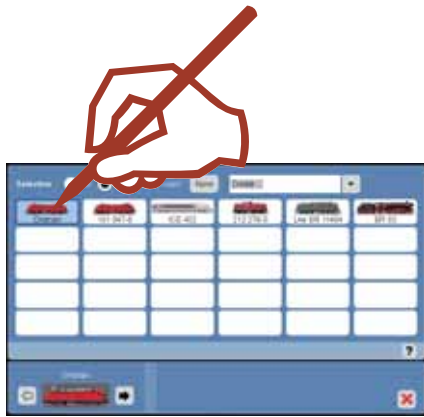

The motive power consist can now be taken into the Control.

The m.u. consist is now available for use. The 2nd controller can now be used for another locomotive or m.u. consist.



You can process the m.u. consist with this tool. Add or remove locomotives as in the 2nd step above.

Deleting a Locomotive or M.U. Consist M DCC

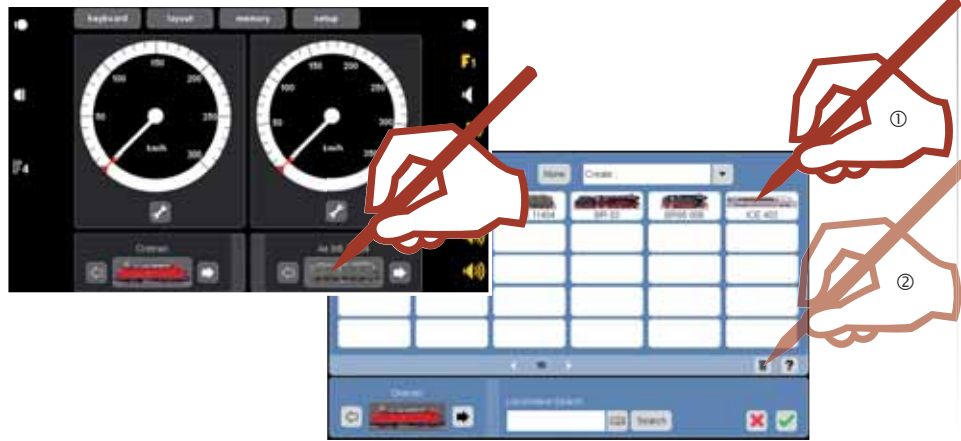

The locomotive or m.u. consist is removed from the locomotive list and is no longer available for use. It must be entered again.

If you have not previously carried out a data protection procedure (backup), the data just deleted are irretrievably lost and can be generated only by entering and setting them up again.



! Now and then you should generate a data backup in the menu "setup". You should always do this data backup after changes to data. You can then produce the old status from this backup and thereby have your locomotive list available again.

Turning off the Central Station: M DCC

Go to the "Setup" menu before turning the Central Station off. Select "Shutdown" and confirm the selection. The "Stop Button" will light up on the controller and the shutdown will begin. The Central Station can be unplugged when the display goes off. The controller begins to shut down. As soon as the door on the locomotive shed is closed, the Central Station can be unplugged.

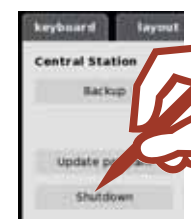

Keyboard

Controlling • Setting Up

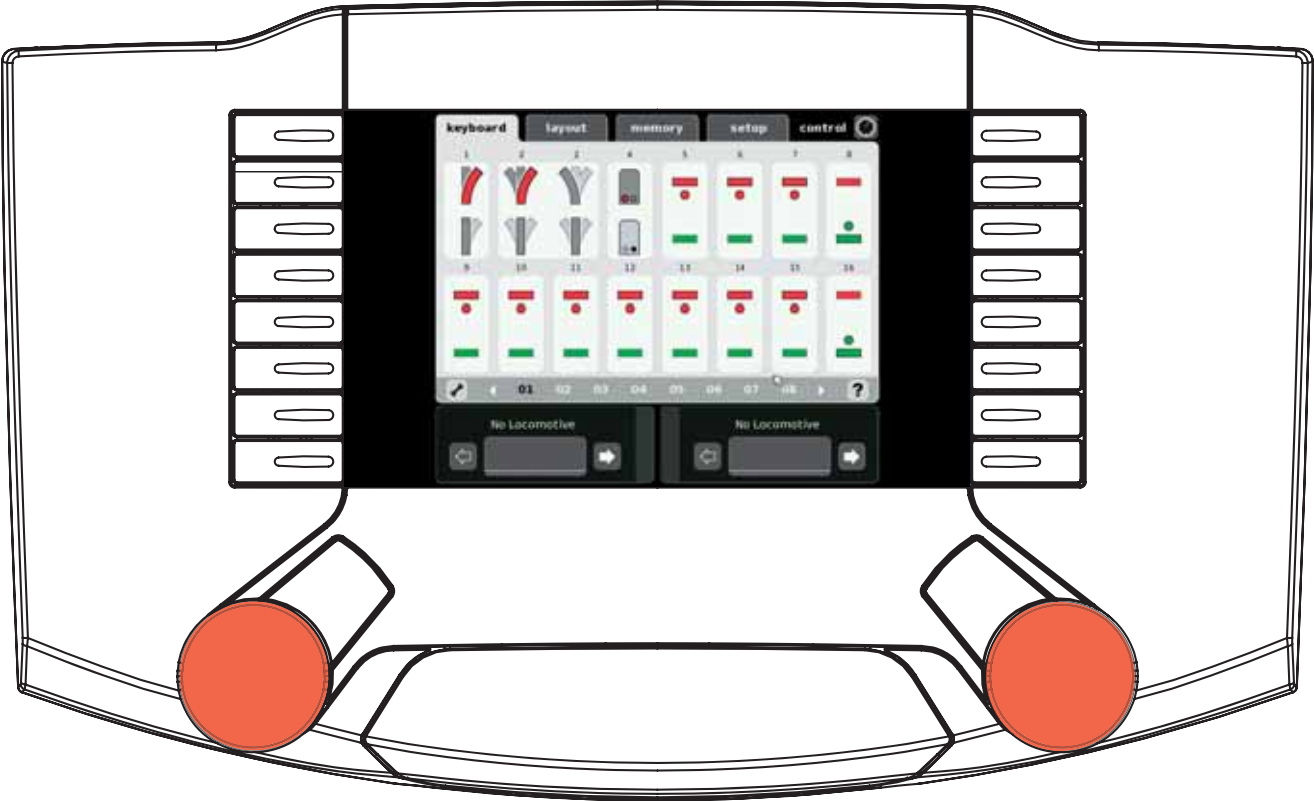

The Keyboard enables you to control and manage all turnouts, signals, turntables, and transfer tables; a total of **(M)** 320 or **(DCC)** 2,048 addresses are available for use.

Controlling Standard Turnouts and Signals **(M)** **(DCC)**

All addresses for the protocol being used are available immediately after the Central Station has booted up and can be controlled using the standard control surface (see illustrations).

Tip: We recommend that you set up the solenoid accessories with the symbols and descriptions that properly go with them in order to have better management of the accessories. See the next section ⇒ Setting up Solenoid Accessories.

Controlling Turnouts and Signals.



Controlling Multiple Position Turnouts and Signals.

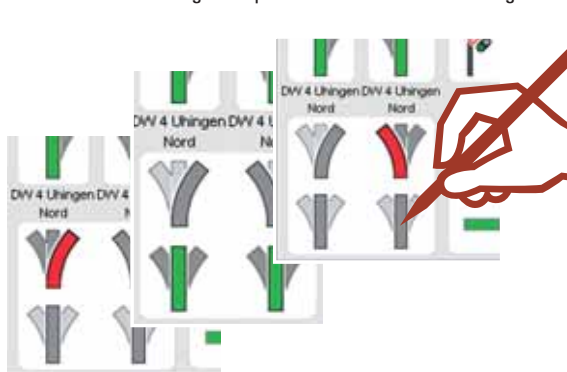

The Keyboard has over **(M)** 20 pages or **(DCC)** 128 pages, each with 16 addresses. These addresses are permanently assigned to the pages and cannot be shifted.

Changing Windows.

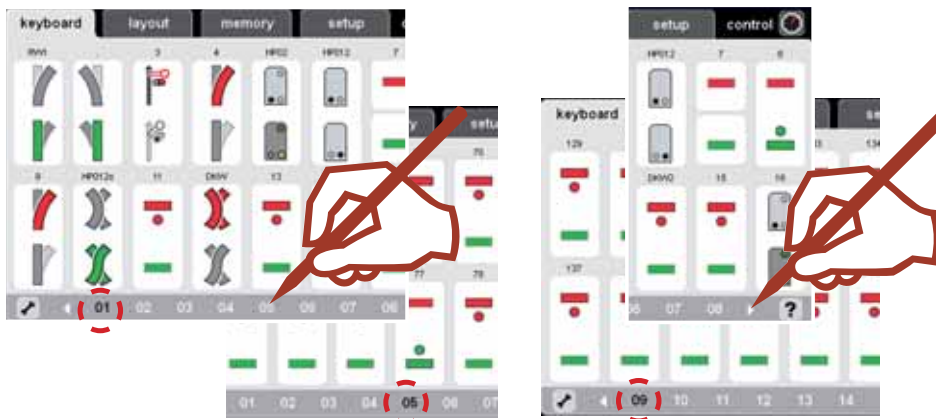

Turntable

Keyboard Window 15 is pre-assigned for the 7686 turntable. Please note that the turntable automatically occupies the 15 following addresses.

You can delete this address assignment if you are not using a digital turntable and thereby free it up for other solenoid accessories.

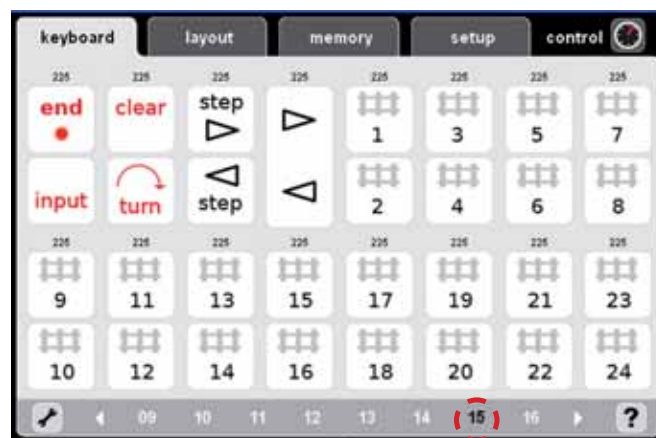

Keyboard:

Setting up Solenoid Accessories • Step by Step. **(M)** **(DCC)**

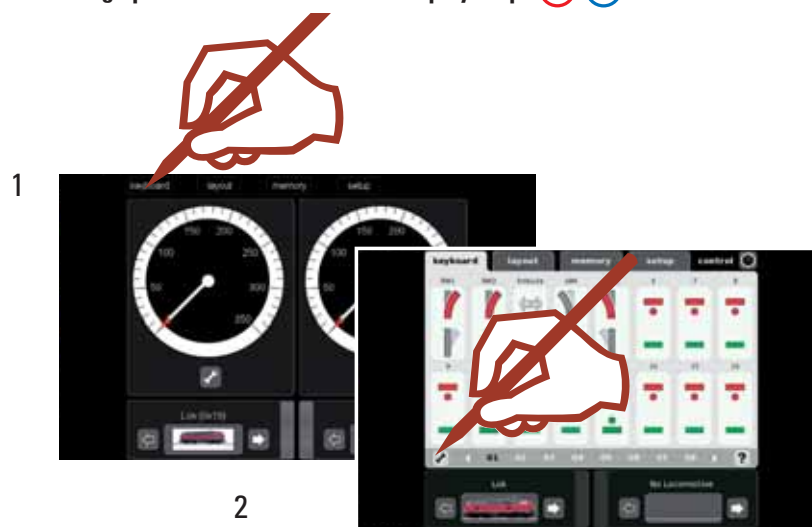

Keyboard: Setting up Solenoid Accessories • Step by Step M DCC

Selecting the Desired Address

3 

4 

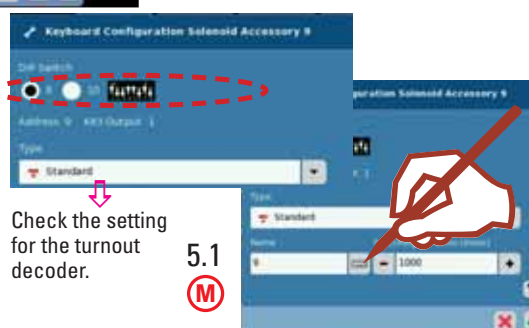
5 M 

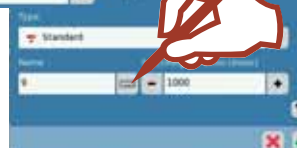
5.1 M 

Check the setting for the turnout decoder.

5 DCC 

5.1 DCC 

Any programming of your DCC turnout decoder must be done according to the instructions for that decoder.

6 

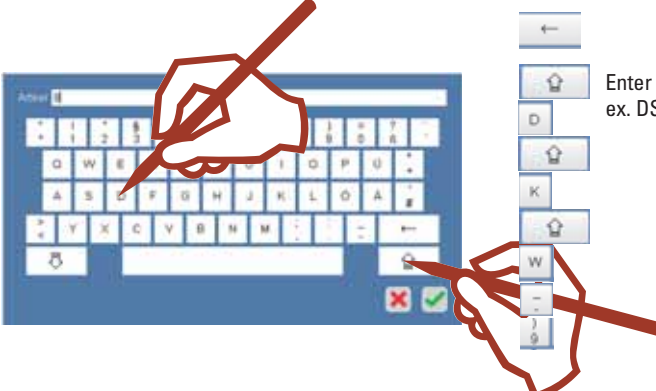
7 

Enter a designation, ex. DSS-9.

8 

Confirm entry

9 

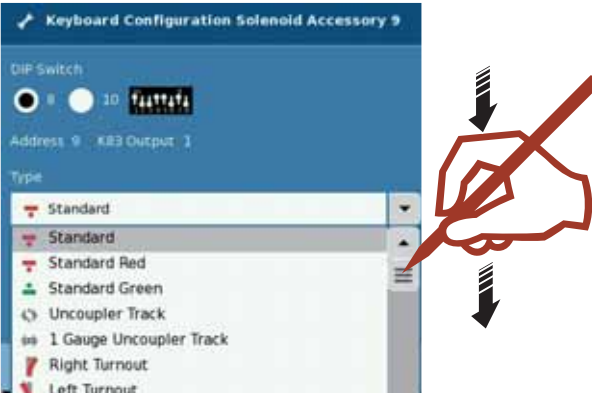
10 

- Standard
- Standard Red
- Standard Green
- Uncoupler Track
- 1 Gauge Uncoupler Track
- Right Turnout
- Left Turnout

11

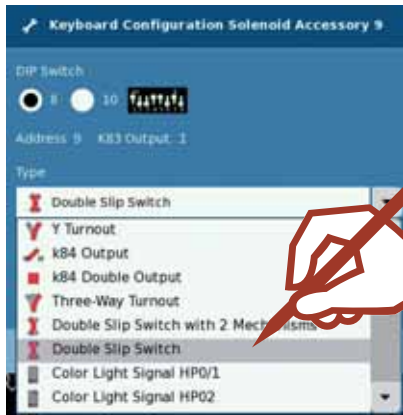

12

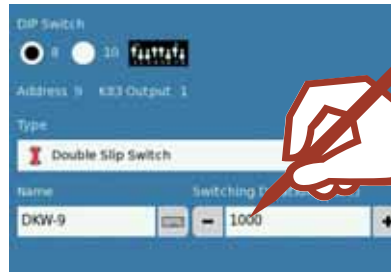

Set the switching duration: We recommend a duration between 250 - 500 milliseconds.

13



Confirm entry

14



Confirm or enter a new accessory (starting at Step ⇒ 4)

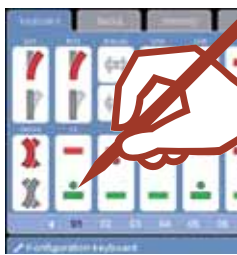

Checking Accessory Function

15



15.1

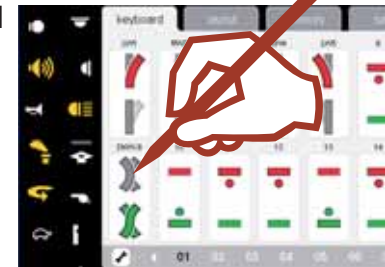

If the turnouts/signals are connected to k 83 decoders (item nos. 6083 or 60830) and the turnout/signal setting does not correspond to the display, then the blue wires for the connection in question must be swapped.

! If the solenoid accessory does not operate despite the correct address, please check the wires at the track connection.



Important Note!

Before you turn the Central Station off, perform the function "Shutdown" in order to ensure that all data has been saved. Turning off the Central Station suddenly may cause loss of the last data to be changed.



Tip:

Basically, the addresses for the decoders can be used in mixed operation. You can decide by address which protocol will be assigned to the latter and which protocol will be supported by the decoder. You can thus use the Märklin professional quality color light signals in DCC operation also.

Programming Professional Quality Color Light Signals.

! No locomotives may be run during the programming procedure. Please note that the programming procedure will be stopped if there are no entries made within 30 seconds.

Set up on your Keyboard beforehand the signals to be programmed as described in Steps 1-13. Enter the switching time at 1,000 milliseconds for the programming procedure. Now click on this symbol  and confirm the messages that come afterward.

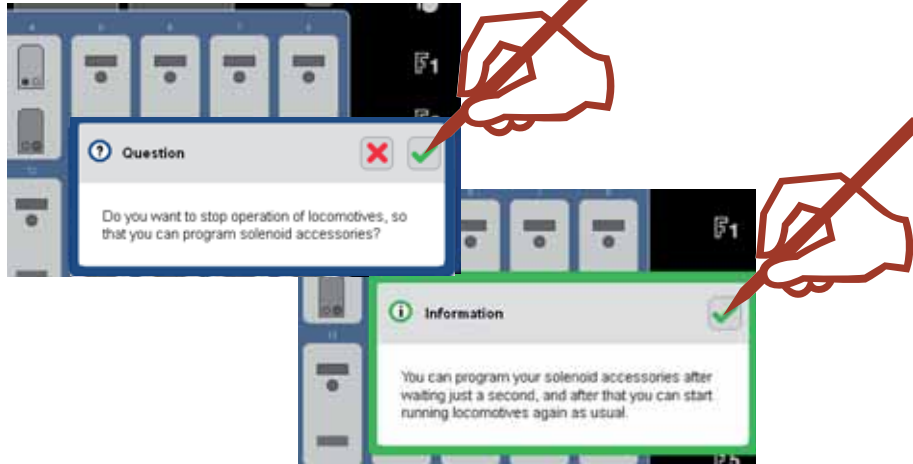

Press the "Stop" button in order to interrupt the current and connect the signal to the main track or to the programming track. Make sure that the wire bracket (programming bracket) surrounded with cardstock is clipped onto the underside of the decoder. Turn the current back on by pressing the "Stop" button again.

Changing signal aspects will now blink in the active programming mode. Now press the signal image for the professional quality color light signal set up on the Keyboard on the Central Station.

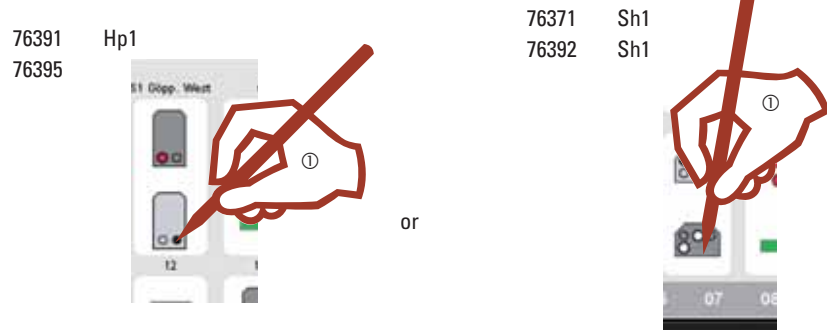

The programming is now complete for a signal with 2 aspects. The remainder of the process can be found further down in the text.

With a signal with more than 2 aspects other signal aspects will alternately blink. The individual steps for these signals can be found in examples further down in the text.

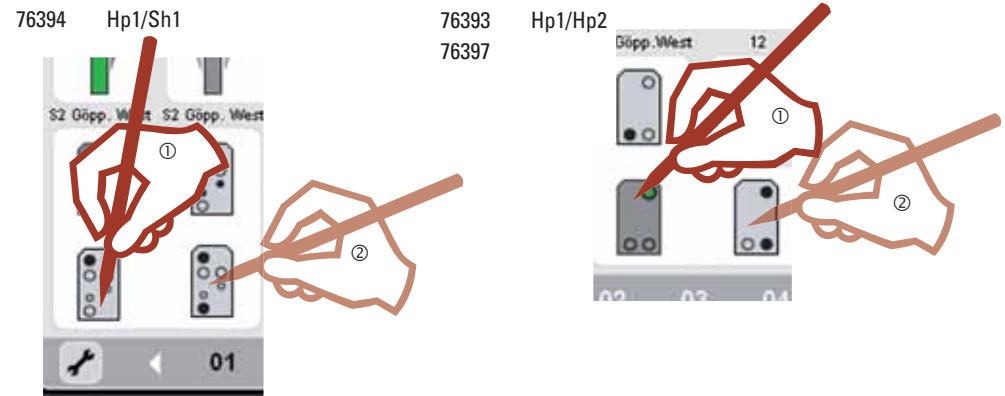

If a distant signal is mounted on the mast of a home signal, this distant signal must now also be programmed.

Now wait until only the distant signal is blinking. Then activate the home signal to which the distant signal is assigned.

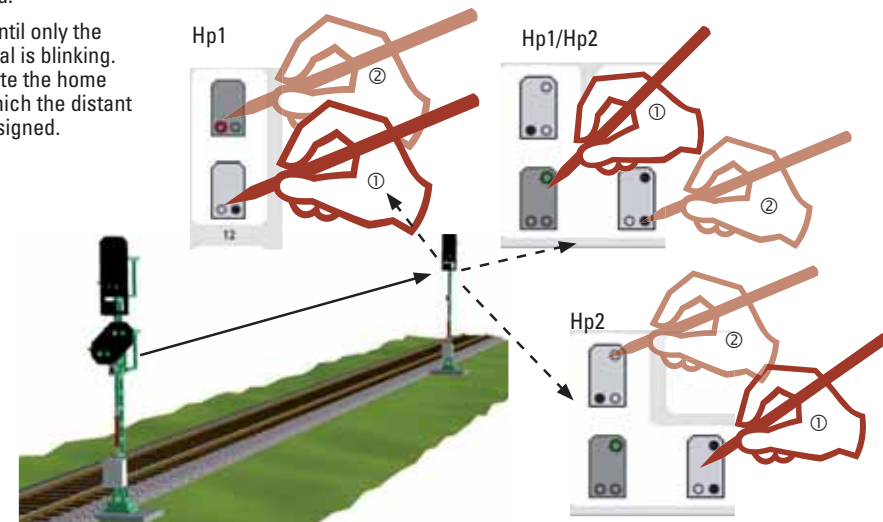

If the signal begins to switch between the signal aspects, the programming procedure is completed. Now press the "Stop" button. The programming bracket can now be removed. Then press "Stop" again. The Central Station is now ready to be operated again.

! Keep the programming bracket; it will be needed in the future for address changes.

Switch to the configuration mode. Now, change the switching duration to 250 milliseconds (Step 12). This is a long enough time for ordinary operation. Change to the operating mode and check to make sure all of the functions of the signal just programmed are working correctly. If necessary, repeat the programming procedure.

Layout

Designing • Controlling

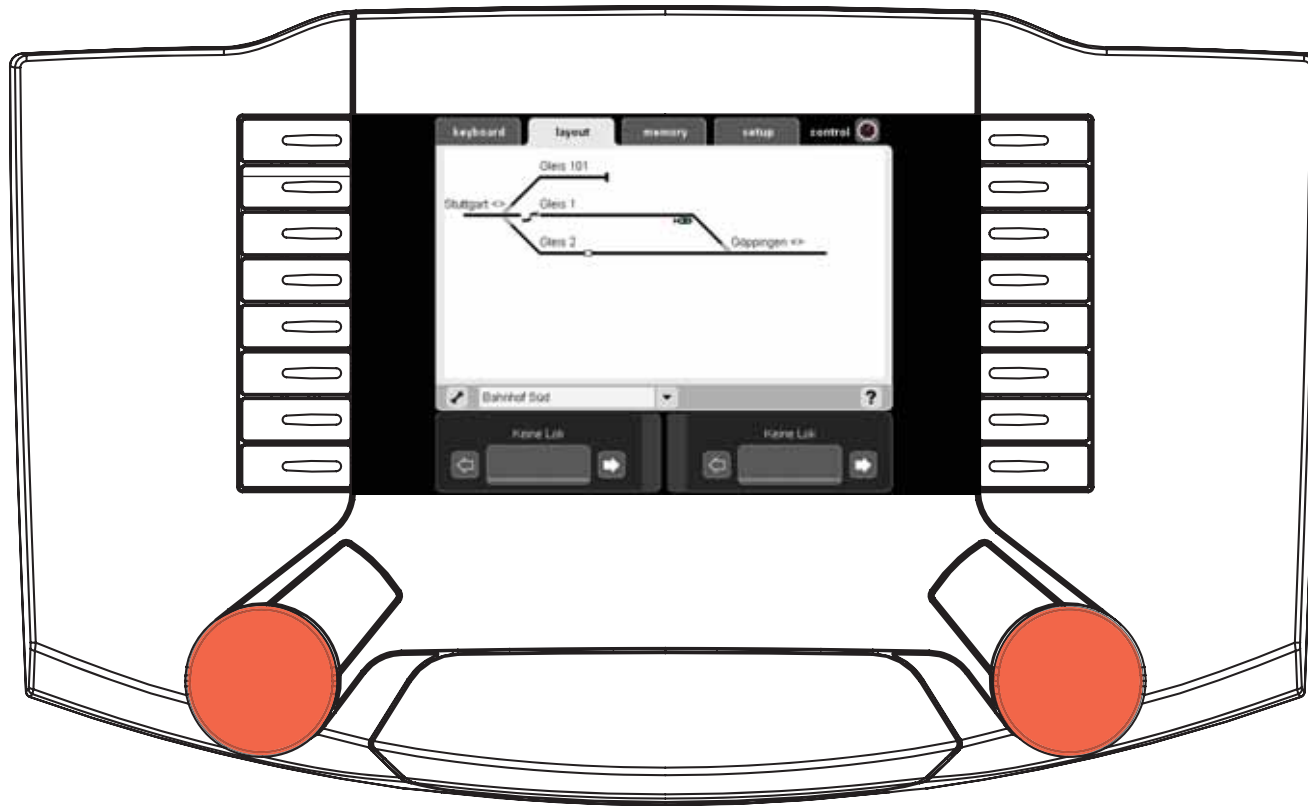

Setting up a Layout.

The Layout level of control on the Central Station simplifies setting up and operating solenoid accessories and routes on a model railroad later on. After a Layout has been set up, turnouts, signals, or routes can be activated by pressing on a symbol. Several Layout pages can be constructed in a Central Station.

We recommend that you set up the appropriate items on your keyboard before setting up the Layouts page.

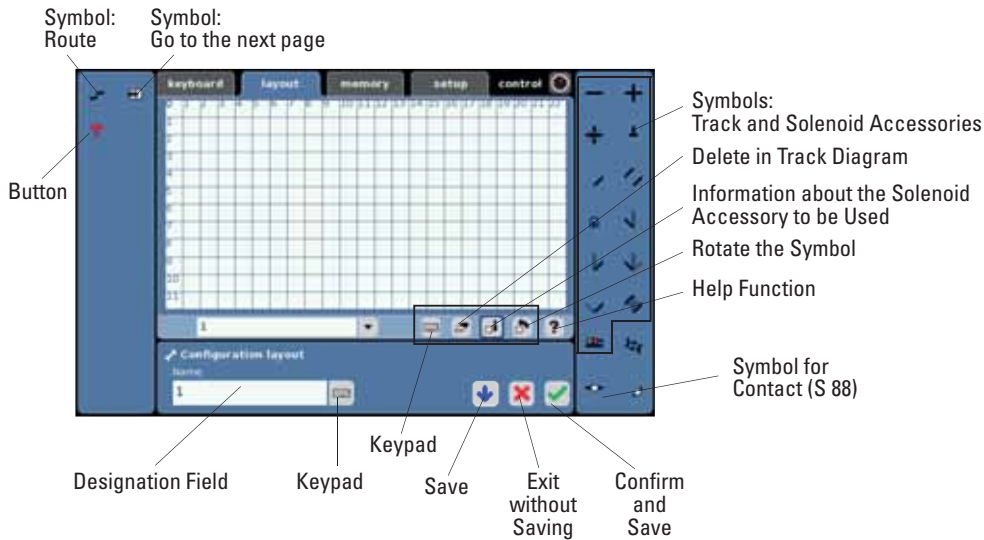
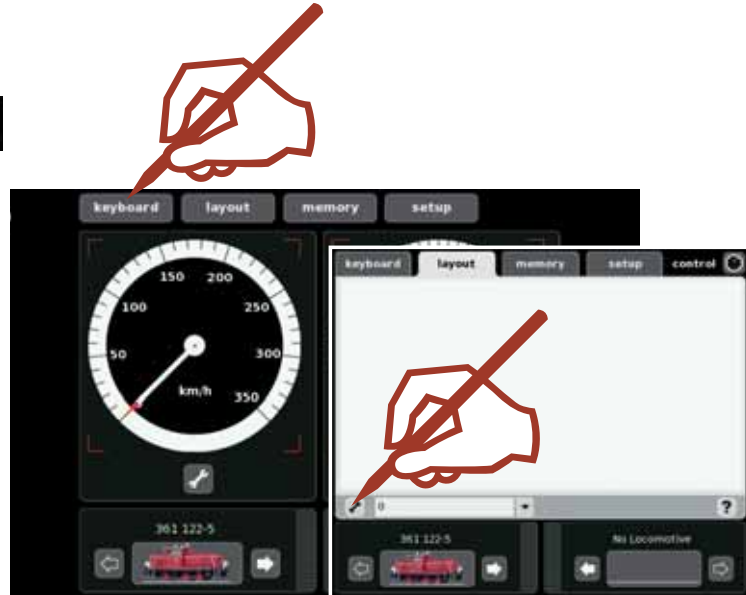

A complete description of the symbols is available in our Help function.

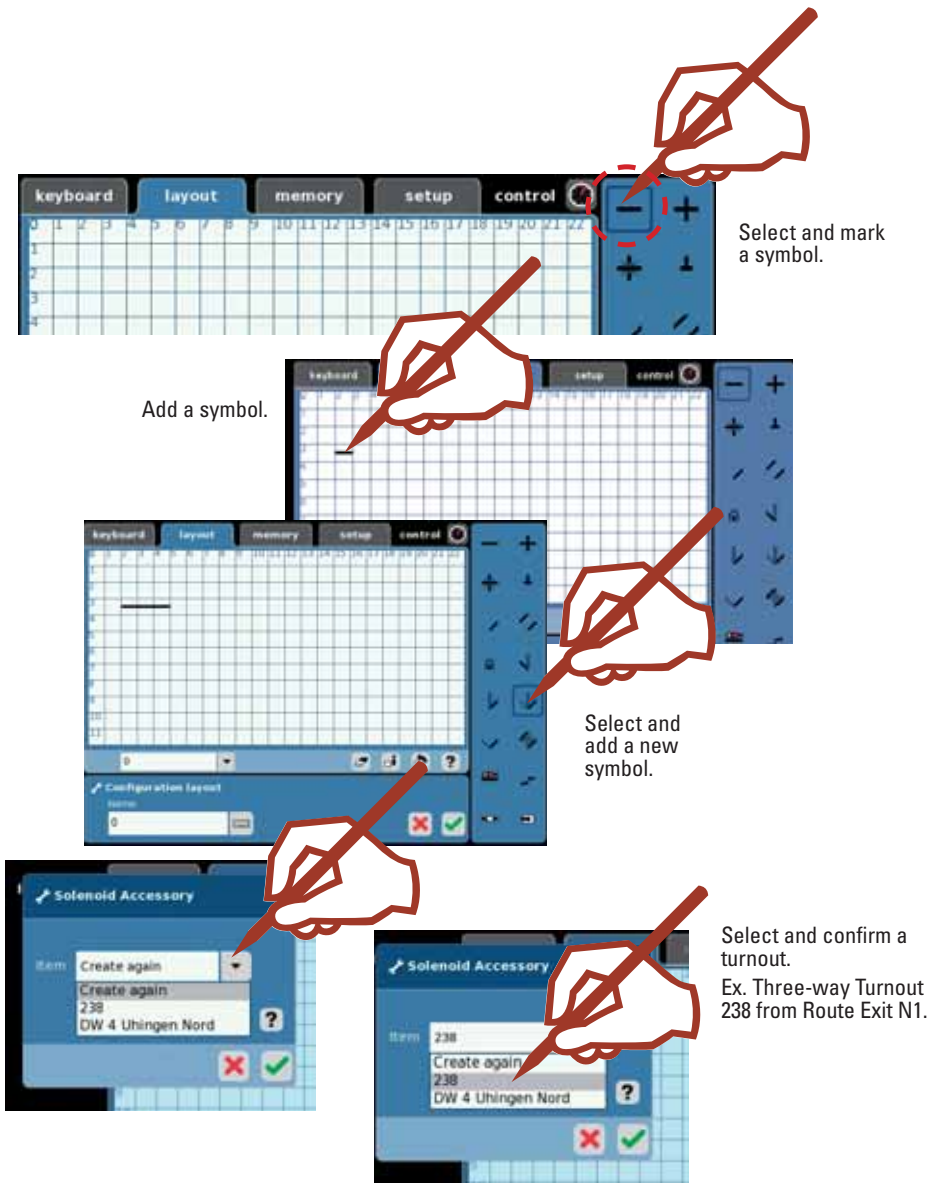

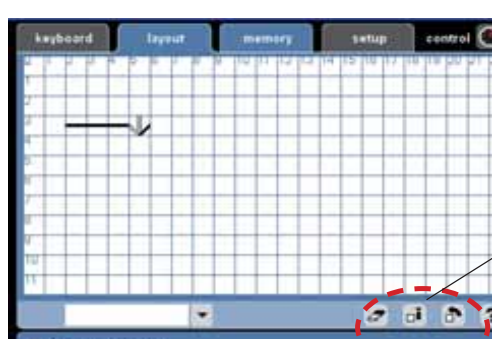

Delete symbol
Rotate symbol

Information about solenoid accessory and change.

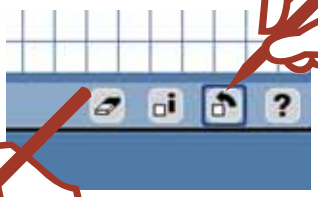

Select the symbol "Rotate".

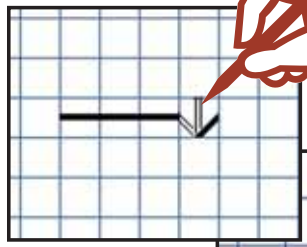

Touch the symbol repeatedly until its position corresponds to the track plan.

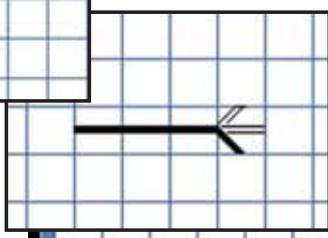

Place additional symbols according to the track plan.

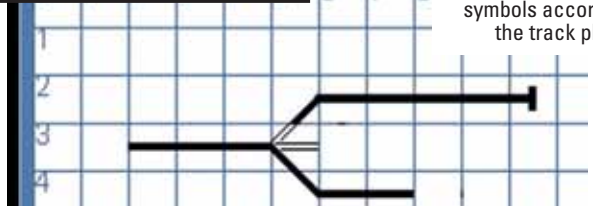

Adding a Route:
In our example there is only 1 route available for use.
If several routes are available, then the desired route can be selected with the arrow button.
Confirm selection.

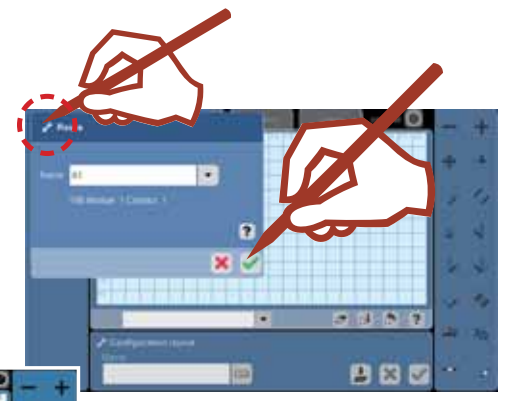

The route has been added.

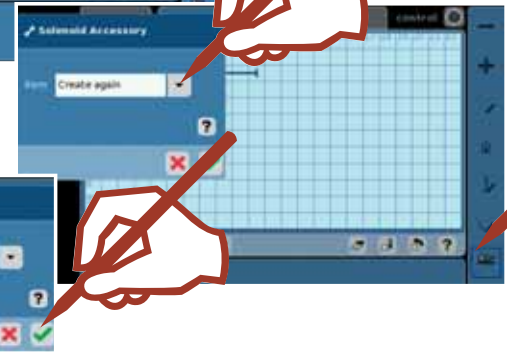
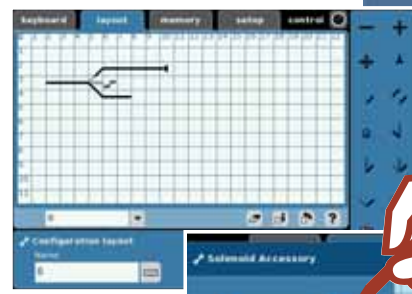

Select signal from the solenoid accessories as before.

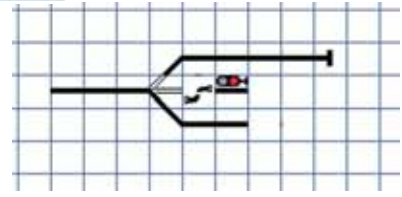

The signal has been added.

If the route is also to be operated by means of an S 88 contact, the latter can also be placed in the Layout.

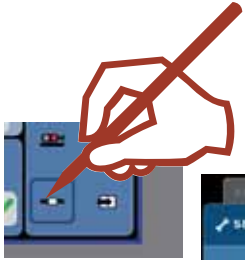

Confirm selection

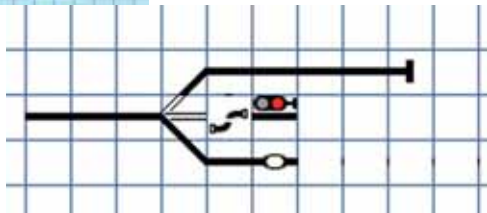

An S 88 contact has been placed in the Layout. Including this contact in the track diagram also allows it to be activated manually.

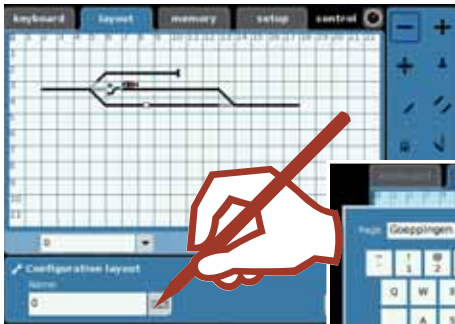

Attach a name to the route (Layout page) with the keypad and then confirm.

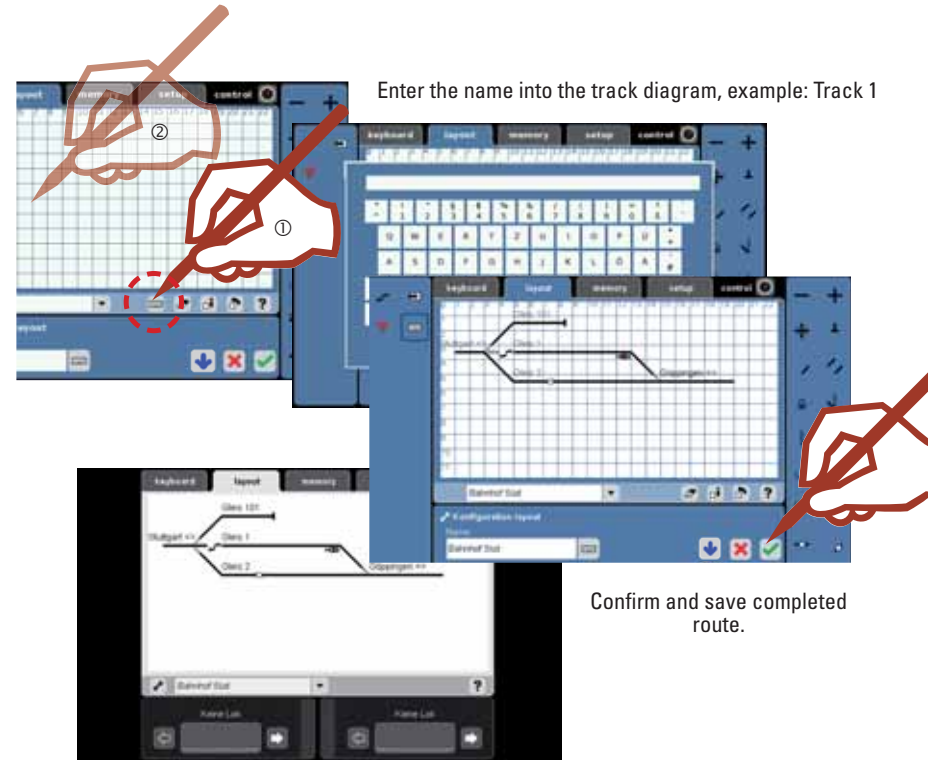

Enter the name into the track diagram, example: Track 1

Confirm and save completed route.

Controlling Accessories with the Layout.

After you have set up your Layout (track diagram) you can control individual solenoid accessories or complete routes by touching the symbols. You can identify the status of particular solenoid accessories from the track diagram.



Important Note!

Before you turn the Central Station off, perform the function "Shutdown" in order to ensure that all data has been saved. Data may be lost, when the Central Station is suddenly turned off.

Memory

Setup • Control

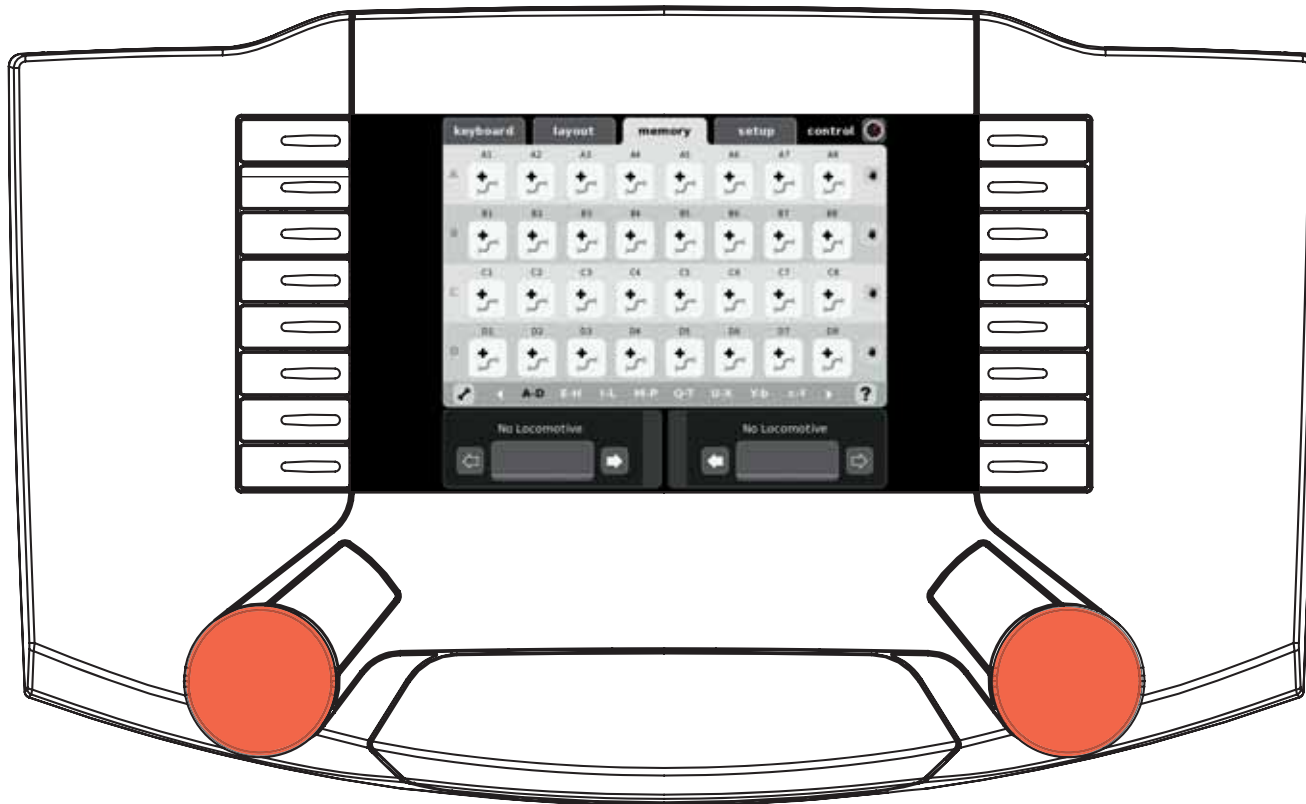

Setting up a Route.

The "Memory" part of the Central Station is used to set up and operate routes on a model railroad. Sixteen Memory windows are available for this function.

We recommend that you set up the appropriate items on your Memories before setting up the Layouts page.

Routes are used so that you can activate several solenoid accessories with the press of a single button. With automatic controls routes are combined with contacts on a model railroad layout in order to control certain processes on a model railroad automatically.

Examples of this are block controls and staging yard controls. More information about this can be found in the Help function.

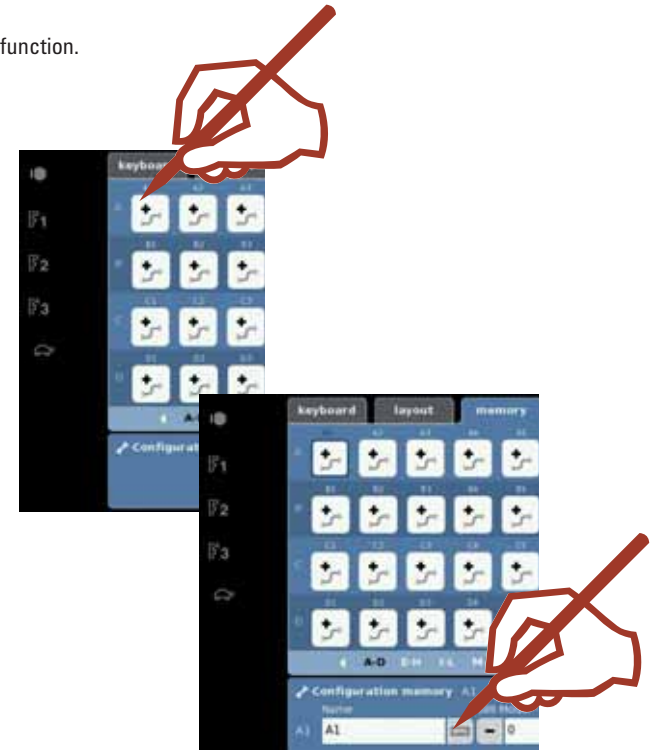

Tip: Enter clear, short names; divide your yard or station into North-South or right-left for example. These names can only be used once.

Example:
Exit N1 = Exit North Track 1

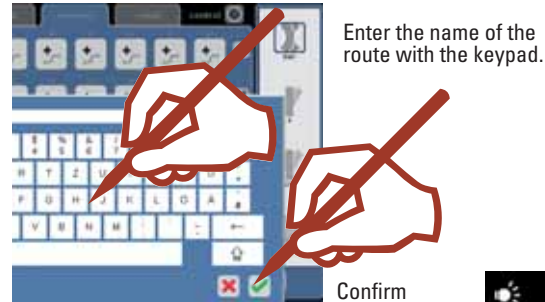
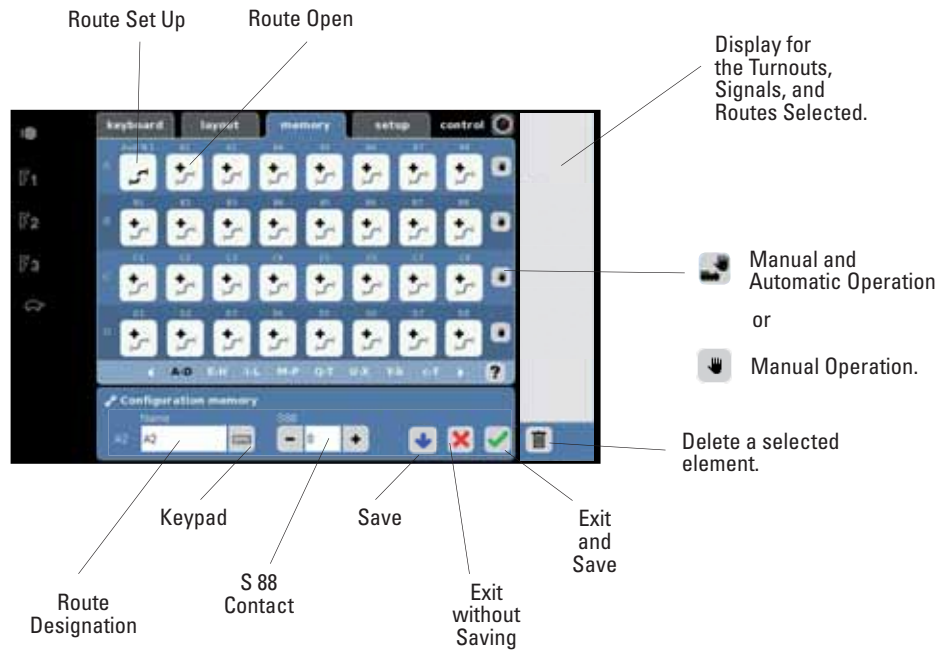

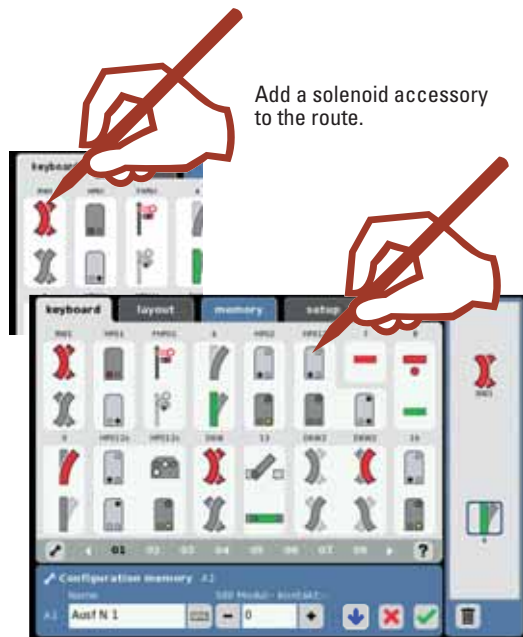

Add a solenoid accessory to the route.

You can add the solenoid accessories from different keyboards to a route. You do not have to adhere to an obligatory sequence. Unclear or in doubt? Use the "?", our help function.

Existing routes can be integrated into a route.

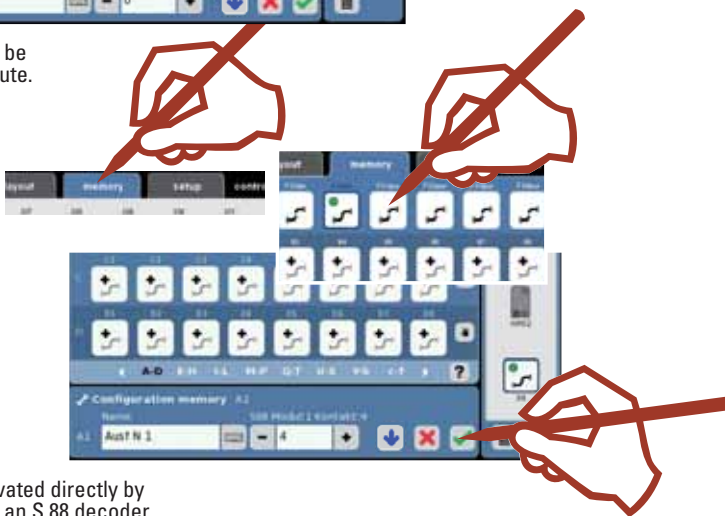

Routes can be activated directly by a train by means of an S 88 decoder. To do this, the appropriate contact output must be entered in the field for the S 88.

✓ End the setting up of the route and save it or save with ↓ and design a new route.

Controlling a Route.

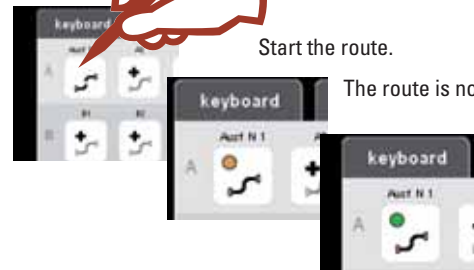

Start the route.

The route is now in the operation mode.

The route is now in operation.

Deleting a Route.



You can deactivate solenoid accessories individually or you can deactivate the route by deleting all of the elements and changing the name to the basic setting (ex. A5).



Important Note!

Before you turn the Central Station off, perform the function "Shutdown" in order to ensure that all data has been saved. Data may be lost, when the Central Station is suddenly turned off.

Setup

Change • Backup • Settings



Setup allows you to adjust the reproduction of data, backup of data, update, reboot, shut down, calibrating, and settings for the Central Station.

Setup 

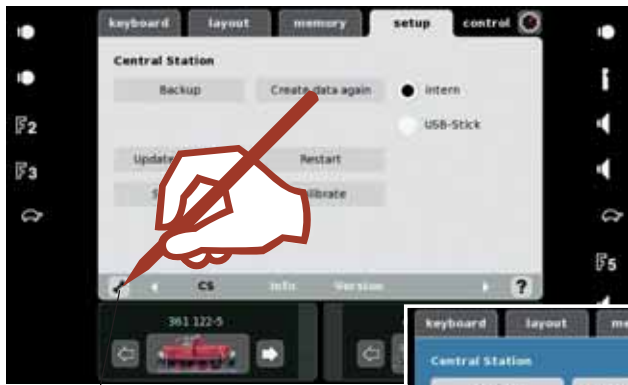

Switch to the processing mode.

Possible Settings for the Central Station

- This Central Station is activated as the main controller.
- This Central Station is being used as a second or auxiliary controller.

The Central Station can be used alone or in conjunction with several Central Stations. When you are using several Central Stations, one must be used as the main controller and the others may only be used as auxiliary controllers.

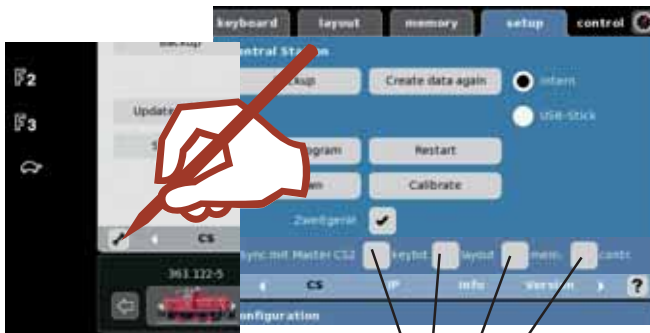
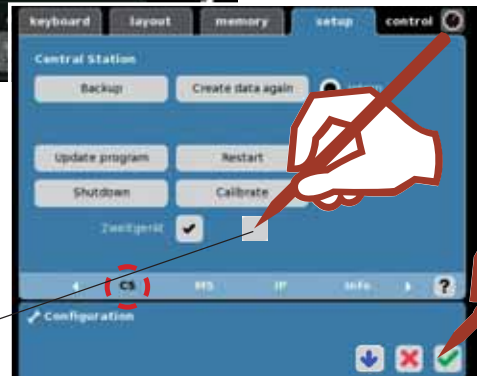

After you have stored the setting in memory as a 2nd or auxiliary controller, you can determine here whether the two controllers are supposed to be synchronized with the master Central Station. You do this by calling up the menu "CS" here. After you have determined whether synchronization has to be done or not, store the setting again in memory.

If the Master/Slave connection is broken and the CS is deactivated as a 2nd or auxiliary controller, the original data for the CS will be present again.

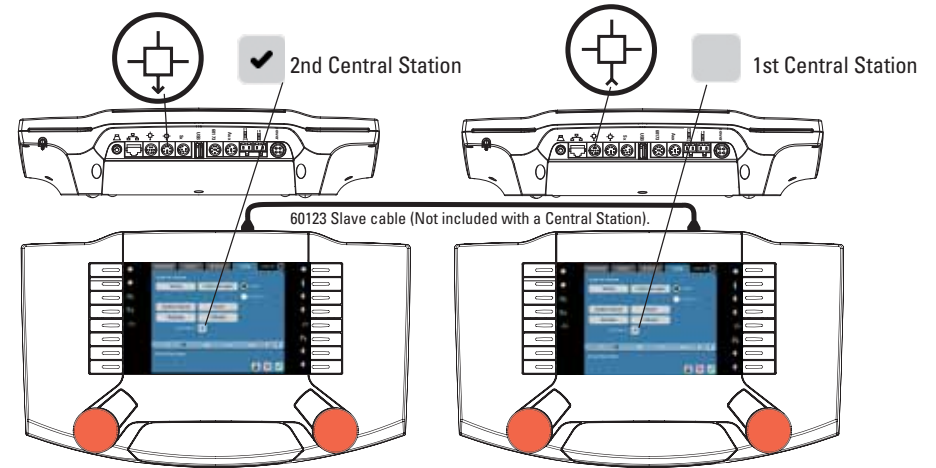

The locomotive list must be set up again in the 2nd Central Station.

Here, you can connect the Central Station to a computer network. More information about this can be found with our help "?".

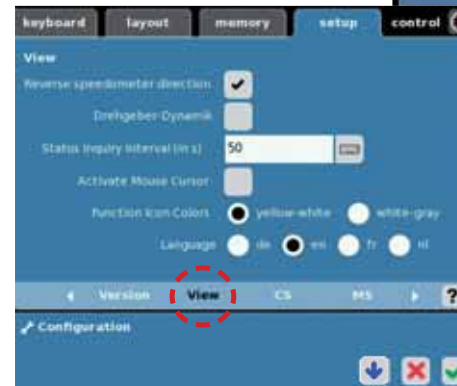

This menu can be used to adapt the Central Station to your personal needs. For example: speed indicator, status inquiry, mouse pointer, function icon color, and language.

Mobile Station 60652

After you have plugged the Mobile Station in, it will register itself automatically. After the registration procedure is over, locomotives can be added to or removed from this Mobile Station. Up to 10 locomotives can be assigned to the Mobile Station.

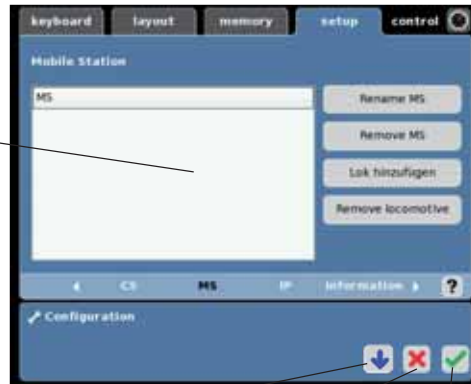

save and process further

exit without saving

save and exit

Mobile Station 60653

See manual of the mobile station 60653

Central Station

Information about your Central Station is displayed here.

It is not possible to make a manual change.



Information about Devices Connected to the Central Station

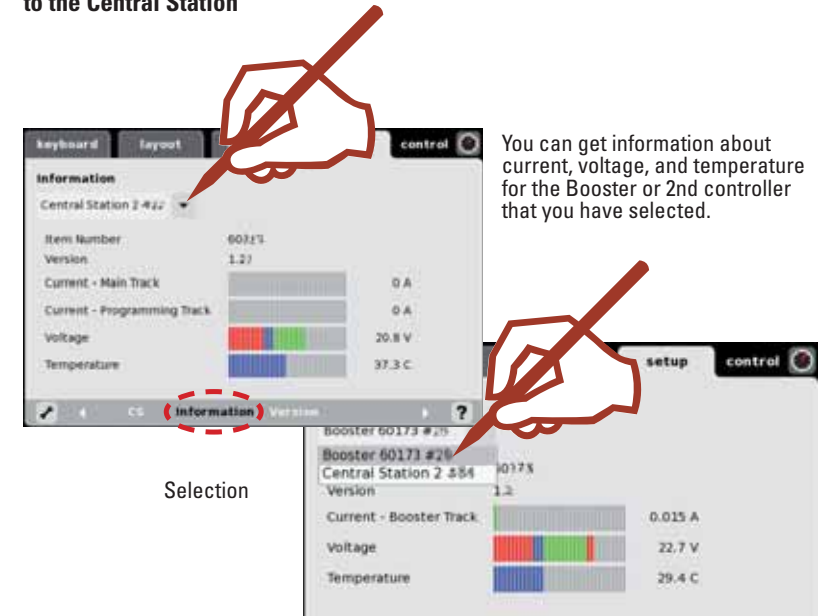

You can get information about current, voltage, and temperature for the Booster or 2nd controller that you have selected.

Selection

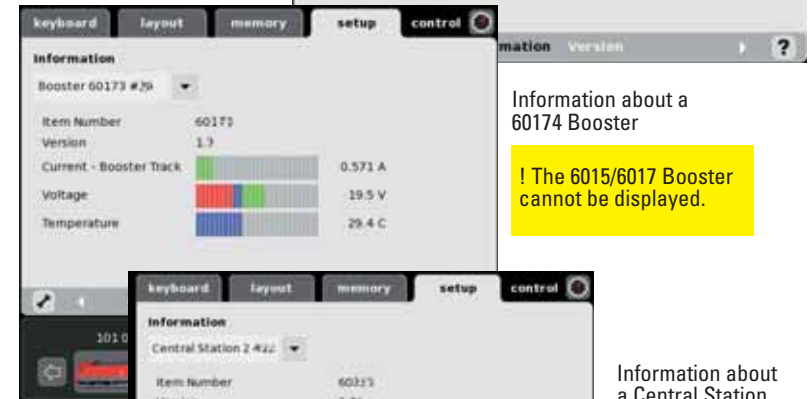

Information about a 60174 Booster

! The 6015/6017 Booster cannot be displayed.



Information about a Central Station

System Architecture

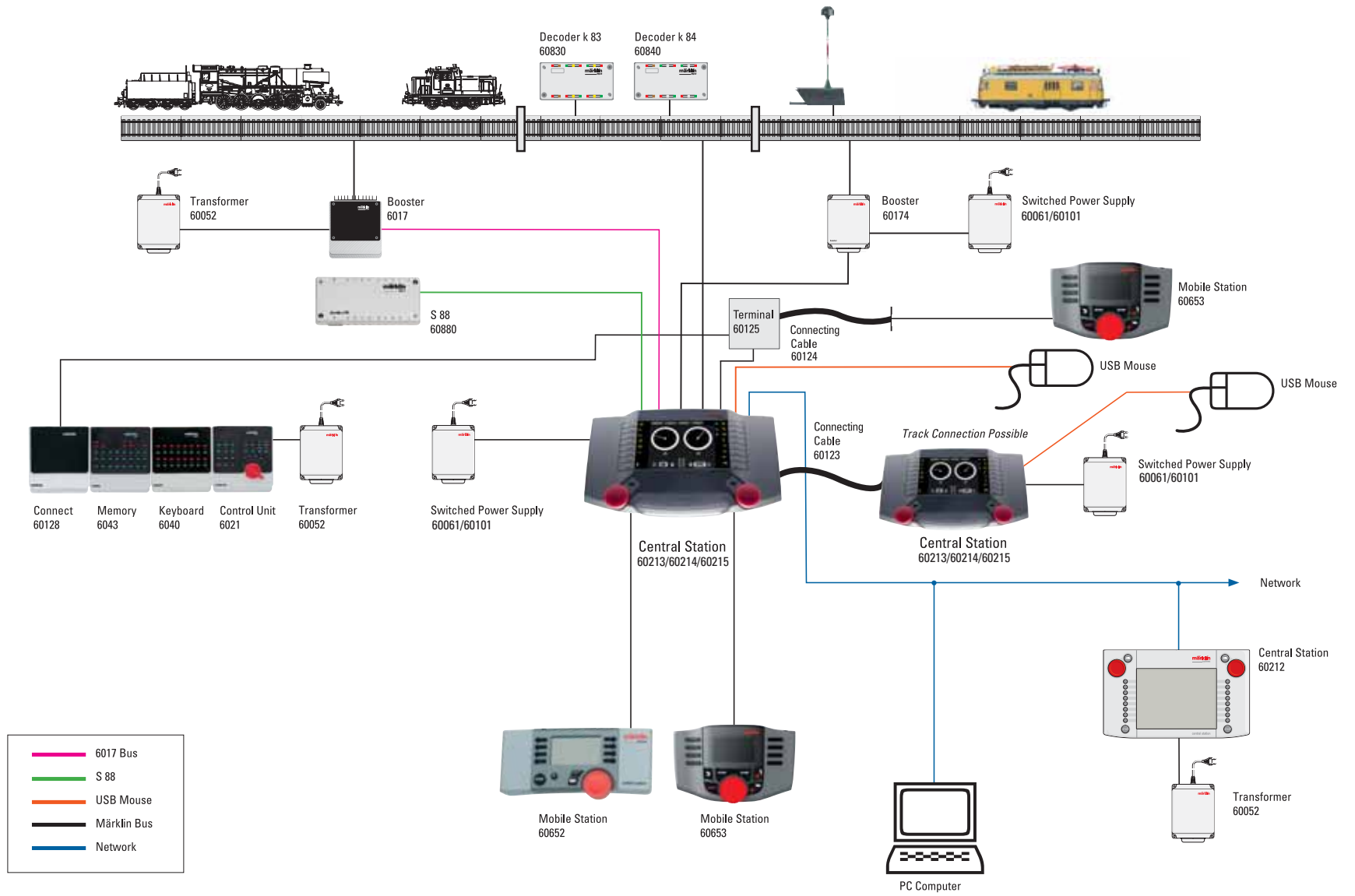

Wireless drive and control is possible with the iPod Touch®, iPhone® or iPad® with a Memory => 32 GB and a wireless router.

How does this work? Get yourself the “Märklin Mobile Station” App (English abbreviation for application) in the App StoreSM and install this application on your controller. Then connect your Central Station to your WLAN router.

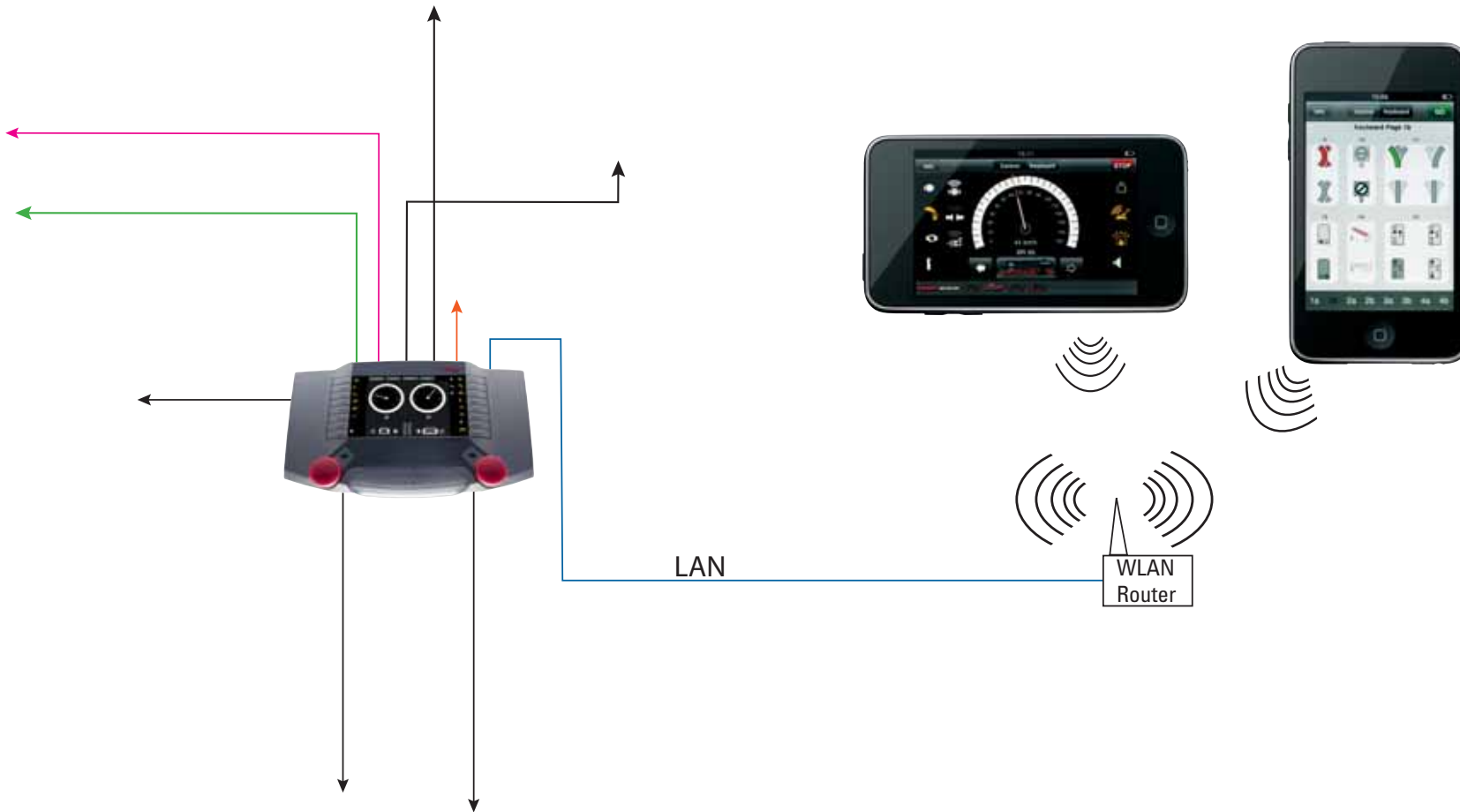

Appendix:

Available Symbols

 Blank	 Acceleration/braking delay	 Table lamps Era III	 Rear Telex coupler	F0 instead of symbol
 End light(s)	 Pump	 Table lamps Era II	 Front Telex coupler	F1 instead of symbol
 Interior lighting	 Brake squealing	 Grate being shaken	 Rear pantograph	F2 instead of symbol
 Marker light(s)	 Relay steps	 Rail joints sounds	 Front pantograph	F3 instead of symbol
 Long distance headlight(s)	 Generator	 Number board	 Rear headlight(s)	F4 instead of symbol
 Sound	 Operating sounds	 Operating sounds	 Front headlight(s)	F5 instead of symbol
 Pantograph	 Motor	 Destination sign	 Raise	F6 instead of symbol
 Smoke	 Station announcement(s)	 Front cab	 Blower motor(s)	F7 instead of symbol
 Switching range	 Coal being shoveled	 Rear cab	 Running gear lights	F8 instead of symbol
 Telex coupler at both ends	 Doors being closed	 Couplers engaging	 Blowing out the cylinders	F9 instead of symbol
 Horn	 Doors being opened	 Buffer impact	 Magnet	F10 instead of symbol
 Conductor's whistle	 Blower motor(s)	 Train announcement(s)	 Up	F11 instead of symbol
 Bell	 Blower motor(s)	 Crane hook	 Down	F12 instead of symbol
 Raise/lower	 Fire box	 Warning light	 Left	F13 instead of symbol
 Turn left	 Interior lighting	 Cab lighting	 Right	F14 instead of symbol
 Turn right	 Table lamps Era IV	 Compressed air		F15 instead of symbol
 Crane				
 Raise/lower crane boom				

Gebr. Märklin & Cie. GmbH
Stuttgarter Straße 55-57
73033 Göppingen
Deutschland
www.maerklin.com

169625/0211/Ha1Gm
Änderungen vorbehalten
© by Gebr. Märklin & Cie. GmbH